SmartTable® OTS™



User's Manual



Newport
Experience | Solutions

Warranty

Newport Corporation warrants that this product will be free from defects in material and workmanship and will comply with Newport's published specifications at the time of sale for a period of one year from date of shipment. If found to be defective during the warranty period, the product will either be repaired or replaced at Newport's option.

To exercise this warranty, write or call your local Newport office or representative, or contact Newport headquarters in Irvine, California. You will be given prompt assistance and return instructions. Send the product, freight prepaid, to the indicated service facility. Repairs will be made and the instrument returned freight prepaid. Repaired products are warranted for the remainder of the original warranty period or 90 days, whichever first occurs.

Limitation of Warranty

The above warranties do not apply to products which have been repaired or modified without Newport's written approval, or products subjected to unusual physical, thermal or electrical stress, improper installation, misuse, abuse, accident or negligence in use, storage, transportation or handling. This warranty also does not apply to fuses, batteries, or damage from battery leakage.

THIS WARRANTY IS IN LIEU OF ALL OTHER WARRANTIES, EXPRESSED OR IMPLIED, INCLUDING ANY IMPLIED WARRANTY OF MERCHANTABILITY OR FITNESS FOR A PARTICULAR USE. NEWPORT CORPORATION SHALL NOT BE LIABLE FOR ANY INDIRECT, SPECIAL, OR CONSEQUENTIAL DAMAGES RESULTING FROM THE PURCHASE OR USE OF ITS PRODUCTS.

First printing 2009

© 2014 by Newport Corporation, Irvine, CA. All rights reserved. No part of this manual may be reproduced or copied without the prior written approval of Newport Corporation.

This manual has been provided for information only and product specifications are subject to change without notice. Any change will be reflected in future printings.

Newport Corporation
1791 Deere Avenue
Irvine, CA, 92606 USA

Table of Contents

Warranty.....	ii
Table of Contents	iii
List of Figures	v
Section 1 – General information	6
1.1 Introduction	6
1.2 Getting Started.....	6
1.3 Unpacking and Inspection	7
1.4 Safety Considerations	7
1.5 System Placement.....	7
1.6 Air Supply Requirements	8
1.7 Warranty Information.....	8
2 Section 2 – Unpacking and Assembly	9
2.1 Unpacking and Inspecting	9
2.2 OTS Frame Assembly	10
2.2.1 Installing Leveling Valves.....	14
2.2.2 Installing the Air Filter Regulator (ARF).....	15
2.2.3 Connecting Air Lines	16
2.3 Squaring and Leveling the OTS Frame	18
2.3.1 Leveling the OTS frame for the rigid (-N) and isolated versions (-I)	18
2.4 Installing the Table:.....	19
2.5 Leveling the table on the frame	20
2.5.1 Leveling the Table on the Rigid (non-isolated - N) version of the OTS System.....	20
2.5.2 Leveling the Table on the Rigid (isolated -I) version of the OTS System	22
2.6 Floating the Table.....	22
2.7 Adjusting Leveling Valve Sensors	23
3 Section 3 – Operation	25
3.1 Principles of Operation.....	25
3.2 Performance Adjustments	25
3.2.1 Stabilizing high center-of-mass loads	25

3.2.2	Improving leveling response times.....	26
3.2.3	Table loads and/or load positions change.....	26
3.3	Maintenance	26
3.3.1	Cleaning.....	26
3.3.2	Air Quality.....	27
4	Section 4 – Troubleshooting	28
4.1	System Does Not Float.....	28
4.2	Poor Isolation Performance	28
4.3	System Oscillates.....	29
4.4	System Leaks Air Constantly	29
5	Section 5 – Factory Service	30
5.1	Obtaining Factory Service	30
6	Service Form	31

List of Figures

Figure 1	OTS leg weldment with shipping bracket being removed.....	11
Figure 2	OTS leg weldments and cross-brace positioning.....	11
Figure 3	Leveling valve mounting holes located on the cross brace should be positioned inward and facing upward toward the top of the frame.	12
Figure 4	Connecting cross-braces to OTS leg weldments	13
Figure 5	Tightening the cross-brace bolts to the leg weldment	13
Figure 6	Completed OTS frame assembly	14
Figure 7	Leveling valve location.....	14
Figure 8	Master Leveling valve installed on cross brace.	15
Figure 9	Location of Master-slave valve.....	15
Figure 10	Air regulator filter (ARF) being installed on leg weldment	16
Figure 11	Pneumatic plumbing diagram for isolated version OTS system...	17
Figure 12	Tubing connection for Master isolator.....	17
Figure 13	Tubing connection for master-slave isolator.....	18
Figure 14	Leveling the OTS frame.....	19
Figure 15	Close up of leveling feet used to level the OTS frame	19
Figure 16	Mounting hole pattern for attaching table to isolator.....	20
Figure 17	Jack screw used to level the rigid OTS system.....	21
Figure 18	Leveling wrenches used for leveling the OTS rigid system	21
Figure 19	Illustration showing positioning of leveling wrenches used for leveling the OTS rigid system.....	21
Figure 20	Safelock clip attachment	22
Figure 21	Close up of OTS isolator floating	23
Figure 22	System stability diagram.....	26

Section 1 – General information

1.1 Introduction

The Newport SmartTable® OTS™ Vibration Isolation Workstation provides an ideal working platform for vibration influenced devices such as interferometers, microscopes, and balances. Sensitive instruments such as these will show significant improvements in resolution and repeatability when isolated from floor motion by the OTS pneumatic suspension system.

Special care was taken to ensure excellent performance in the 10-50 Hz floor vibration frequency range corresponding to dominant ambient vibration frequencies common to multi-floor buildings. The OTS pneumatic isolators provide excellent protection against both vertical and horizontal floor motions.

These workstations integrate Newport's rigid, laminated honeycomb panel SmartTable technology and pneumatic isolation systems to provide a mounting platform which is rigid, yet thin and lightweight. The system accommodates high-center-of-gravity loads with exceptional stability. Equipped with casters, the system is easy to move without heavy equipment.

It is possible to tailor the system to a wide variety of applications using the range of sizes and the many optional storage and safety accessories.

1.2 Getting Started

Please read this instruction manual thoroughly before assembling the isolation system. The individual components have been assembled at the factory and require only final system assembly and performance adjustment.

You can find demo set-up videos on Newport's YouTube Channel. Search "SmartTable OTS Demo" on YouTube to start, or scan the QR code below:

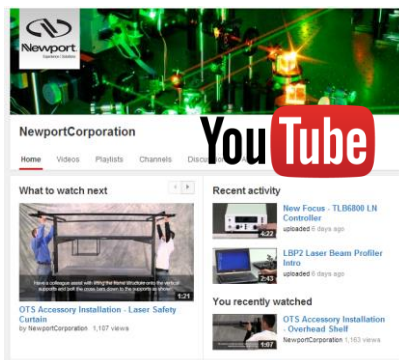

1.3 Unpacking and Inspection

The components of your Newport Vibration Control System are packed in individual, labeled boxes. Carefully inspect all components for shipping damage.

Report any shipping damage immediately to Newport and the shipping company.

1.4 Safety Considerations

The following terms are used in this manual that relate to your safety.

	<p style="text-align: center;">WARNING</p> <p>Warning is used to indicate dangers that could result in personal injury.</p>
---	--

	<p style="text-align: center;">CAUTION</p> <p>Caution is used to indicate situations that may result in damage to components of your Newport Vibration Control System.</p>
---	---

1.5 System Placement

To ensure optimal performance from your OTS Vibration Isolation System, it should be located on a level surface. Uneven floors or mounting surfaces may cause difficulty if their irregularity is outside of the range of the leveling feet.

The OTS isolators must be mounted so that its axis is not more than 0.5 degrees from vertical. This is necessary for the isolator to function properly in the horizontal mode. Note: 0.5 degrees is equal to 0.05 (1.3 mm) inches in 6.0 inches which is the isolator base dimension. A typical spirit level will easily measure 0.5 degrees and can be used to check the vertical alignment of each isolator.

If the floor where the isolators are being mounted has a depression of more than 0.05 inches under one side of the base, then the floor should be grouted or shimmed level at this location.

If the system is not located on the ground floor of the building, it should be located near primary vertical structures such as exterior walls or support columns. By locating the table near these structures, the effects of low frequency floor motion will be minimized, thus increasing isolator performance. It is also advisable to avoid locations adjacent to major sources of vibration from operating machinery such as elevators, air conditioning plants, or factory equipment.



WARNING

The payload is attached to the isolators with bolts. In the event of an earthquake, the system may collapse. For areas susceptible to earthquakes, we recommend that earthquake restraints be installed on each vibration control system.

1.6 Air Supply Requirements

A constant supply of air must be connected to the isolators during operation. After initial setup and filling, the isolators consume air only when the leveling valves adjust the pressure to compensate for changes in the load on the table.

Bottled nitrogen or mechanically compressed air may be used. The required pressure is determined by dividing the total load, including table weight, by the total isolator diaphragm area (9.5 in² per isolator) plus 5-10 psig.

For example, if the table plus load is 2850 pounds and will be mounted on 4 isolators, the required pressure is:

$$1850 \text{ lbs}/(4 \times 9.5 \text{ in}^2) + 10 \text{ psig} = 59 \text{ psig.}$$

Note that the maximum operating pressure for the system is 90 psig (6.3 kg/cm²).

The Newport Model ACWS/ACGP air compressor is an extremely quiet source of clean, pressure regulated air. If another compressor or plant air is used, the Newport model ARF Air Regulator/Filter should be used to ensure maintenance free operation. These filters prevent water and dirt from getting into the leveling valves and causing the valves to fail due to clogging.

The supply should include a shut off valve so that the air may be shut off during maintenance or extensive setup when the load is changed drastically.



CAUTION

Bottled carbon dioxide (CO₂) is not recommended since “icing” can occur during rapid filling of the isolators.

1.7 Warranty Information









Warranty information may be found on the page preceding the Table of Contents in this manual. Should it become necessary to exercise the warranty, contact your Newport representative to determine the proper course of action. Newport Corporation maintains offices throughout the United States and other locations worldwide. Refer to the back cover of this manual for the addresses and telephone numbers of these offices.

2 Section 2 – Unpacking and Assembly









2.1 Unpacking and Inspecting









Unpack the SmartTable OTS leg assemblies, the cross-braces and all of the hardware. Inspect all of the parts for shipping damage. There are 2 different versions of the OTS system; rigid and isolated. The parts shipped with your SmartTable OTS vibration Isolation system are shown below.

Isolated (-I) Version

	Description	Qty
	OTS cross braces and leg weldments	3 braces, 2 leg weldments
	IPV Leveling valve	3
	ARF Air regulator and mounting bracket	1
	1/4" translucent air line tubing	40 feet
	Tee connector	3
	Safelock clips and mounting screws	12 sets
	1/4-20 7/16 Hex head screws	24
	3/8" wrench	1
	Black flat washer	24

Rigid (-N) version

	Description	Qty
	OTS cross braces and leg weldments	3 braces, 2 leg weldments
	1 1/8 open end frame leveling wrench	2
	Safelock clips and mounting screws	12 sets
	Isolator leveling wrench	1
	Hex head screws	24
	Black flat washer	24
	1/4" locking washer	24
	7/16" wrench	1
	Bubble level	1

Isolated (-I) Version Continue		
	1/4" locking washer	24
	7/16" wrench	1
	Bubble level	1
	Tubing mounting clips	10
	1 1/8" open end frame leveling wrench	2
	Black hole plugs	100
	1/4" Black tubing	40 feet
	1/4 NPT male tubing adaptor	1
	M5 x 0.8 SHCS	6 (36mm) 2 (10mm)

2.2 OTS Frame Assembly

The SmartTable OTS leg assemblies are shipped bolted together via two shipping brackets. These brackets keep the OTS leg assemblies upright during shipping.

Remove the two shipping brackets using the 7/16" wrench included with your OTS system. Each bracket has 4 bolts that must be removed.



Figure 1 OTS leg weldment with shipping bracket being removed



Figure 2 OTS leg weldments and cross-brace positioning

Roughly position the OTS leg assemblies. The distance between the assemblies should be about the length of the cross-braces. Cross-brace length is roughly 5, 7, 9 feet depending on the size of your system.

	<p>WARNING</p> <p>Two people will be required to safely assemble the OTS frame.</p>
---	--

The cross-brace used on top (2 pcs.) each has 2 holes drilled in it. These holes are used to mount the leveling valve brackets and should be positioned inward. The cross-brace used on bottom (1 pc.) has multiple 8-32 holes

drilled in it for users to mount accessories and should be facing upward (see **Error! Reference source not found.**).

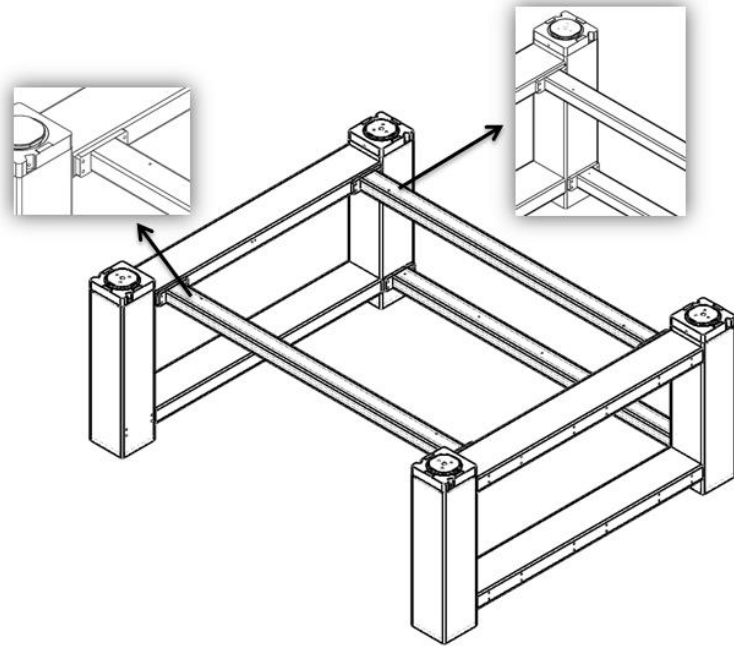

Figure 3 Leveling valve mounting holes located on the cross brace should be positioned inward and facing upward toward the top of the frame.



Figure 4

Connecting cross-braces to OTS leg weldments

Bolt the cross braces, one at a time, to the OTS frame assembly using the 1/4" bolts, washers and lock washers provided with the OTS frame. Use the 7/16" wrench to tighten the bolts to a torque of 6 ft-lbs.



Figure 5

Tightening the cross-brace bolts to the leg weldment

	CAUTION
<p>Do not over tighten. The bolts can be stripped if excessive force is used. Tighten to a torque of 6 ft-lbs.</p>	

After all the cross braces are tightened, place bubble level on both sides of the frame and adjust the leveling feet as needed (see Figure 6 and Figure 14).



Figure 6

Completed OTS frame assembly

2.2.1 Installing Leveling Valves

If your frame is the non-isolated (-N) version you do not have leveling valves. Please skip this section of the assembly instructions. Go to section 2.3.

If your OTS system is the isolated version (-I) three leveling valves will need to be mounted to the cross braces. Note that only three leveling valves are needed since three points define a plane. The diagram in Figure 7 shows the location for the leveling valves.

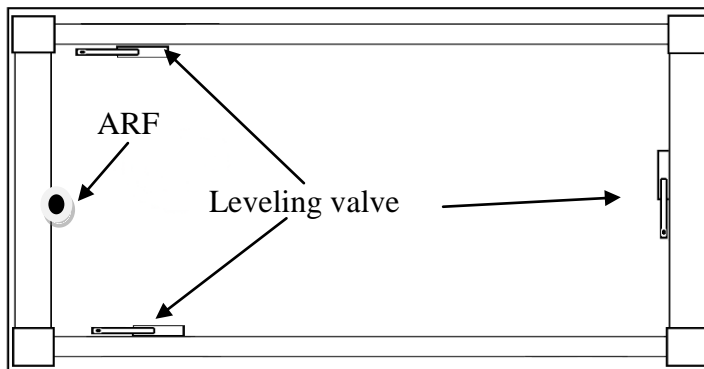

Figure 7

Leveling valve location

Two sets of holes have been pre-drilled and tapped in the frame cross braces. One set has been drilled in the leg weldment. Attach brackets using 3/8 wrench first. Attach the leveling valves to the bracket and use a 4mm allen wrench to tighten the M-5 socket head cap screws that came with the leveling valves. See figure 7 for valve location.

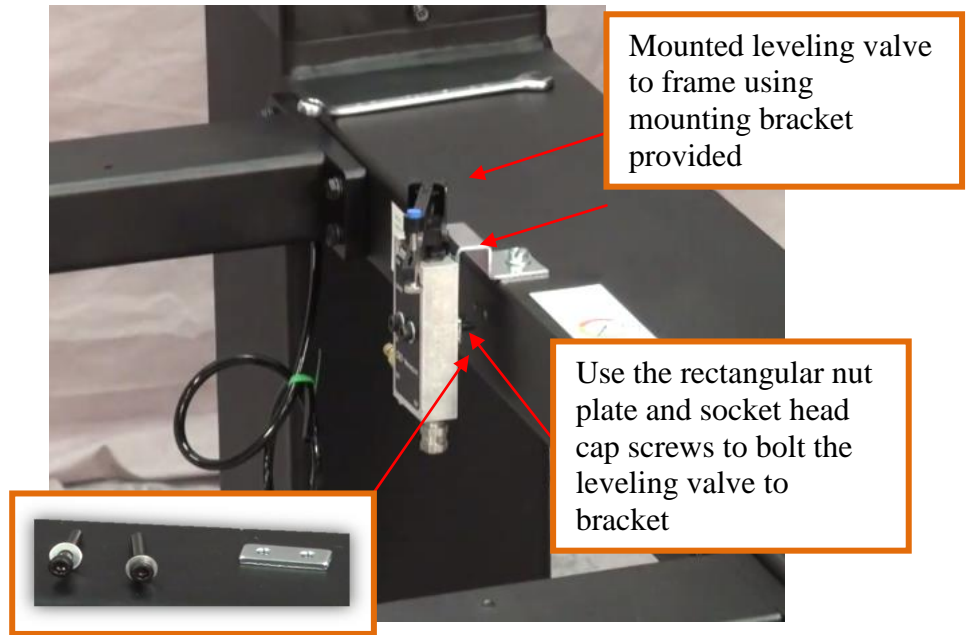

Figure 8

Master Leveling valve installed on cross brace.

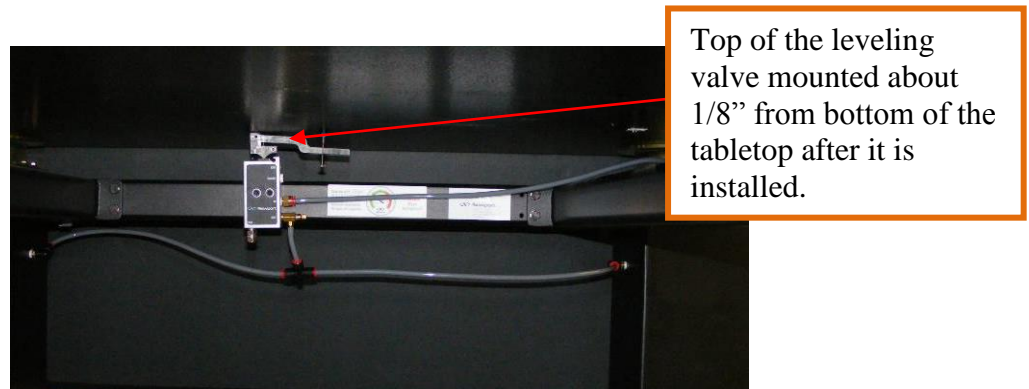

Figure 9

Location of Master-slave valve

2.2.2 Installing the Air Filter Regulator (ARF)



Figure 10

Air regulator filter (ARF) being installed on leg weldment

Attach the ARF air regulator to the mounting bracket. Attach the mounting bracket to the OTS leg assembly (Figure 7 and Figure 10). Use the 4mm allen wrench to tighten the two M-5 socket head cap screws.

2.2.3 Connecting Air Lines

The IPV leveling valve is shown in Figure 12. Three valves are used in all systems as only three points are required to determine a plane. The leveling valve locations are selected such that they form the largest triangle possible under the table. The larger the triangle, the more stable the system will be. When two or more isolators are controlled by the same valve, they act as a single large isolator supporting the table at the center of force of the several isolators. The floating height of the system is determined at the valve position.

Connect air lines to the isolators as shown in Figure 11, Figure 12 and Figure 13. When cutting tubing, be sure the ends are round and cut squarely. This is best done with a single edge razor blade (scissors will deform the tubing, causing leaks). The connections are detailed in Figures 11, 12 and 13.

Use translucent tubing to connect the air supply to the ARF. Be sure the connections are firm by tugging on the tube.

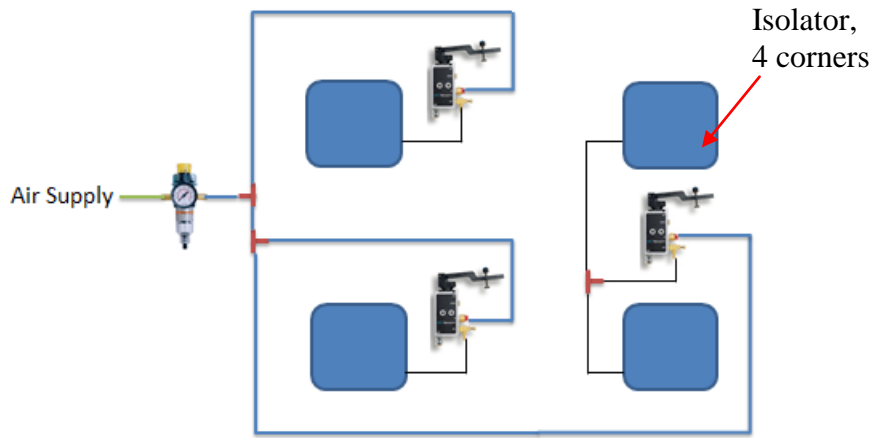

Figure 11

Pneumatic plumbing diagram for isolated version OTS system

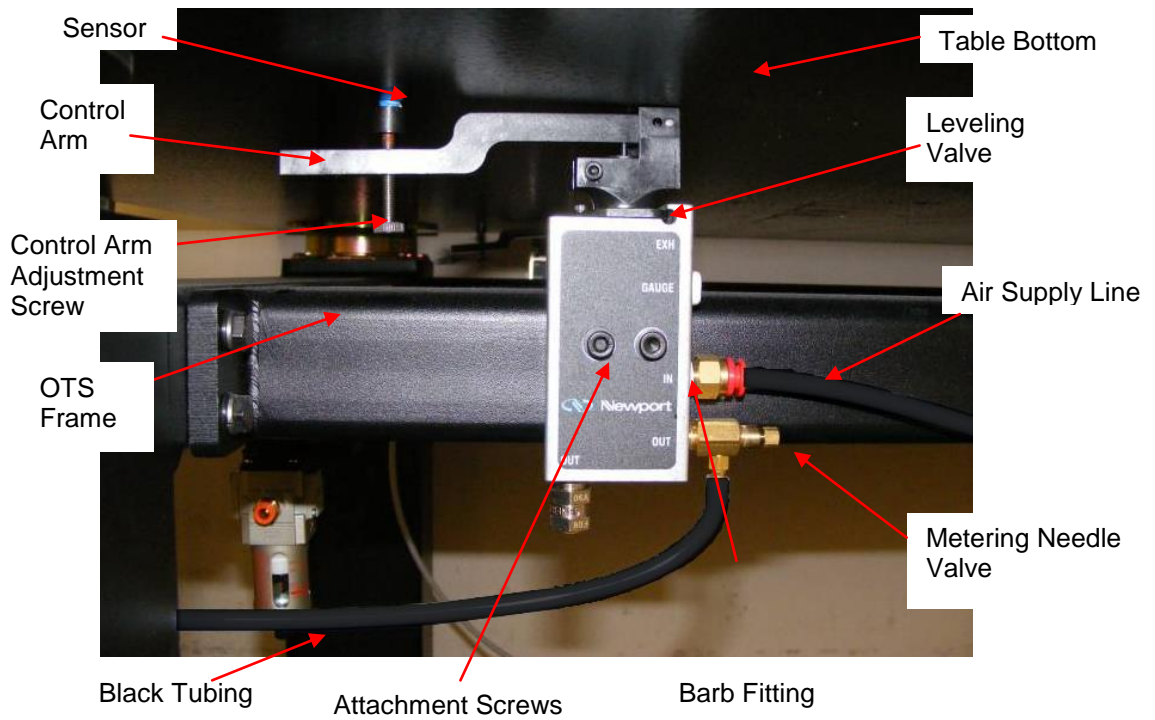

Figure 12

Tubing connection for Master Isolator

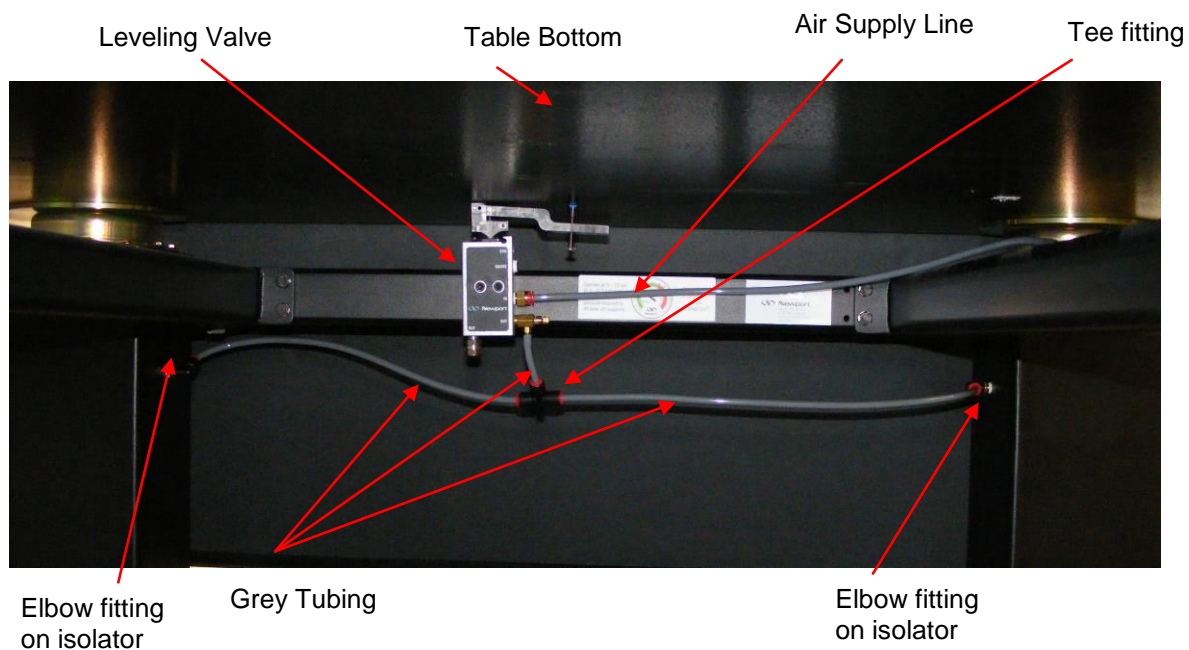

Figure 13

Tubing connection for master-slave isolator

2.3 Squaring and Leveling the OTS Frame

2.3.1 Leveling the OTS frame for the rigid (-N) and isolated versions (-I)

Place the bubble level on the OTS frame as shown in Figure 14. The level measures if the frame is level in the X-Y plane. Use the 1^{1/8}” open end wrenches provided to adjust the four leveling feet until the frame is level (Figure 15). One wrench is used to hold the lock nut while the other is used to rotate the bolt. This will either raise or lower the table depending on the direction the bolt is rotated. Adjust the leveling feet until the frame is level.



Figure 14 Leveling the OTS frame



Figure 15

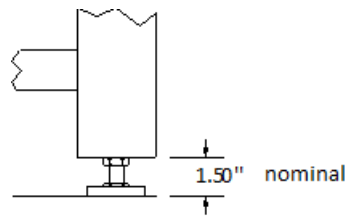

Close up of leveling feet used to level the OTS frame

2.4 Installing the Table:



WARNING

Payloads are heavy! Use a forklift or other appropriate equipment. Be sure to use proper lifting procedures to avoid severe personal injury.

With the OTS frame assembled and leveled as described in Section 2.2, raise the table and position it above the OTS frame. Be sure the frame is correctly positioned relative to the attachment holes provided in the bottom of the table. See Figure 16.

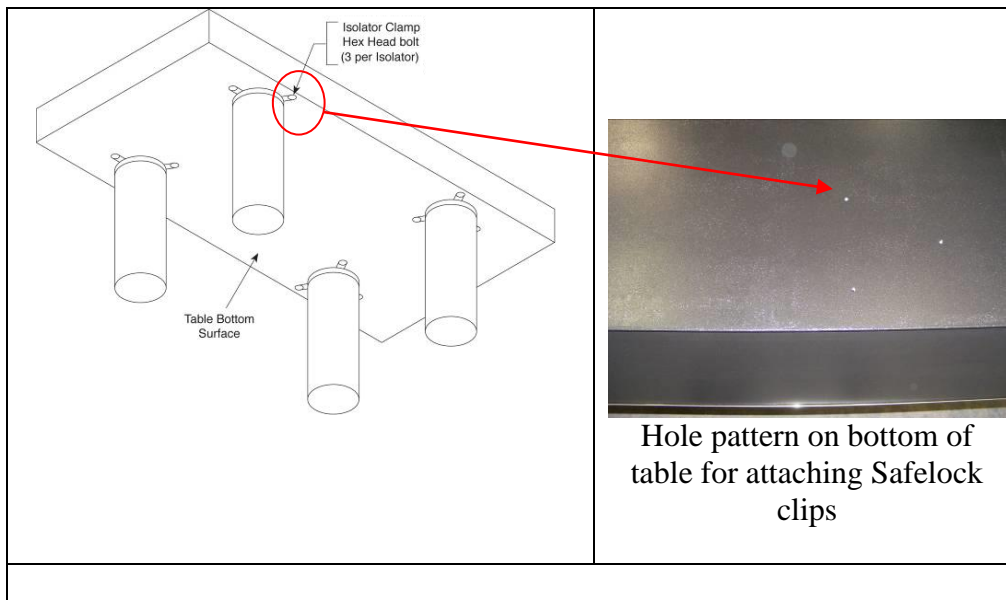



Figure 16

Mounting hole pattern for attaching table to isolator

	<p>CAUTION</p> <p>When lowering the payload on to the isolators, do not allow the payload to shift sideways. Doing so could damage the isolators.</p>
---	--

Position the table so the bolt hole patterns line up over each isolator (see Figure 16). Slowly lower the table to within $\frac{1}{2}$ " of the OTS frame. Slight adjustment of the OTS frame positioning may be necessary in order to achieve proper alignment for the isolator and bolt hole pattern on the bottom of the table.

2.5 Leveling the table on the frame

2.5.1 Leveling the Table on the Rigid (non-isolated - N) version of the OTS System

Adjust the four leveling jack screws (Figure 17, Figure 19) using the spanner wrench (Figure 18) until the table top contacts evenly on all four of table supports and does not rock when pressed down on at any of the four corners. Make sure all 4 isolator leveling feet are still in contact with floor. The isolated (-I) version of the OTS does not have or require this adjustment. Use the Safelock clips and clip bolts to attach the table support to the table (see Figure 20). The opposite end of the spanner wrench used to adjust the jack screw can be used to tighten these bolts.



Figure 17 Jack screw used to level the rigid OTS system

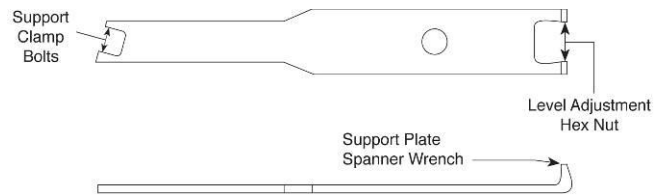

Figure 18 Leveling wrenches used for leveling the OTS rigid system

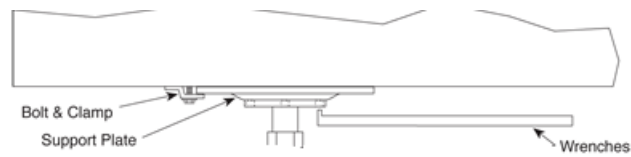

Figure 19 Illustration showing positioning of leveling wrenches used for leveling the OTS rigid system

*Figure 20**Safelock clip attachment*

2.5.2 Leveling the Table on the Rigid (isolated -I) version of the OTS System

Make sure the table is resting on all four table support plates and does not rock when pressed down on at any of the four corners. If this is the case, attach the Safelock™ clips as described in section 2.6.2, Figure 20. Make sure all 4 isolator leveling feet are still in contact with floor.

If the table is not in contact with all four support plates and rocks, adjust the appropriate leveling foot for isolated (-I) version or jack screws of the supporting plate for rigid version (-N) until the table support is in contact with the bottom of the table. Once all four support plates are in contact with the bottom of the table and all four leveling feet are in contact with the floor use the Safelock clips and clip bolts to attach the table support to the table (see Figure 20). The opposite end of the spanner wrench used to adjust the jack screw can be used to tighten these bolts.

2.6 Floating the Table

1. Close the metering needle valve (Figure 12) on each isolator then open it ½ turn.
2. Turn on the air supply and adjust the regulator for the pressure calculated using the formula given in Section 1.6. This pressure must not exceed 90 psig (6.3 kg/cm₂).
3. Check all connections for leaks. Correct or repair any leaks before proceeding. If the table does not float within several minutes, increase

the air pressure until the table floats or adjust the valve height sensors to hold the control arms further down. Confirm that the needle valves are open $\frac{1}{2}$ turn per isolator supplied. NOTE: If the table oscillates after it floats, decrease the air pressure or close the needle valves slightly. In clean room applications the “EXH” (exhaust) port on the valves may be connected to the clean room vacuum system to capture the valve exhaust. NOTE: Exhaust must be routed to a vacuum system. Backpressure in the tubing will cause the exhaust air to leak from the valve.

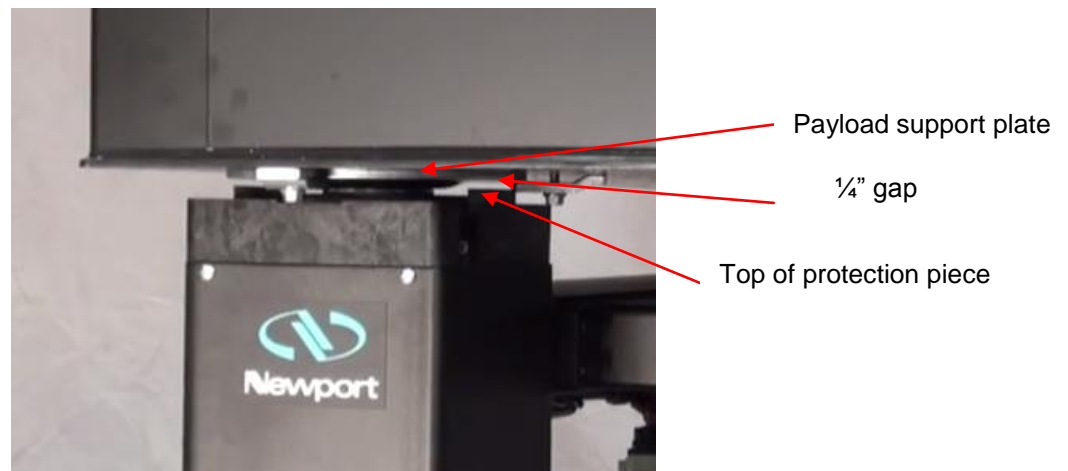

Figure 21

Close up of OTS isolator floating

2.7 Adjusting Leveling Valve Sensors

1. After the system floats, check the position of the payload support plate for all isolators (see Figure 21). The gap between the bottom of payload support plate and the top of the protection rubber piece should be about **1/4 inch nominal (6 mm)**.
2. Adjust the control arm adjustment screw of each valve (Figure 12) as required to obtain this gap. When all isolators are adjusted, re-check the level of the payload. NOTE: this step should require only minor adjustments. Do not move the small set screw near the pivot of the valve control arm.
3. Verify that the table is freely floating on the isolators. Move the table gently from side-to-side about $\frac{1}{8}$ inch. You should not encounter any resistance. Re-check by moving the table up and down the same amount. Again, there should be no restriction of movement.
4. Push one corner of the table down approximately $\frac{1}{8}$ " and release it. The table should return to the original position within less than 4 seconds. Response time may be adjusted as described in Section 3.2.2.

5. If the table rocks back and forth (oscillates vertically) without settling down close all of the needle valve adjustment screws. Then re-open the screw by $1/8$ to $1/4$ turn.
6. In each corner of the table gently push down on the table top. The table should lower and then return to its starting position. Gently push up from the bottom of the table. The table should slightly rise then return to its original position. If the table does not move freely either up or down adjust the height adjustment screws in the leveling valves until the table moves freely.

3 Section 3 – Operation

3.1 Principles of Operation

Newport Isolators provide one of the best methods of vibration isolation for critical applications. The system operates on the principle of air pistons, which are equivalent of soft springs. The main advantage of the Newport system over other designs are low vertical resonant frequency with low amplification at resonance (Q) and a Pendulum™ horizontal decoupling system for effective isolation from low amplitude vibration.

The leveling valves provided with the system control the height of the table to within ± 0.01 inch (0.3mm) accuracy. This tolerance is adequate for most applications. More accurate valves are available for specialized applications.

3.2 Performance Adjustments

Once the system is assembled and floating, it is possible to make minor adjustments to suit your individual needs. These adjustments involve the system air pressure, the control arms, and needle valves.



WARNING

Once the system is floating, keep fingers away from the area between the support plate and the top of the isolators. Any object between these points may be caught if the load or air supply changes. Personal injury may result.

3.2.1 Stabilizing high center-of-mass loads

If your load has a high center of mass or if the load is particularly heavy, the system may oscillate. In this case, lower the air pressure or close the needle valves slightly. This may improve stability and reduce the oscillation or “hunting”.

A rule of thumb for determining high center of gravity (C-G) system stability is shown in Figure 22. If the combined center of gravity of the payload is within the “stable region”, the system will be stable. If the combined C-G is inside the “may be stable region”, the system may be stable. If the combined C-G is outside both regions, the system will probably be unstable.

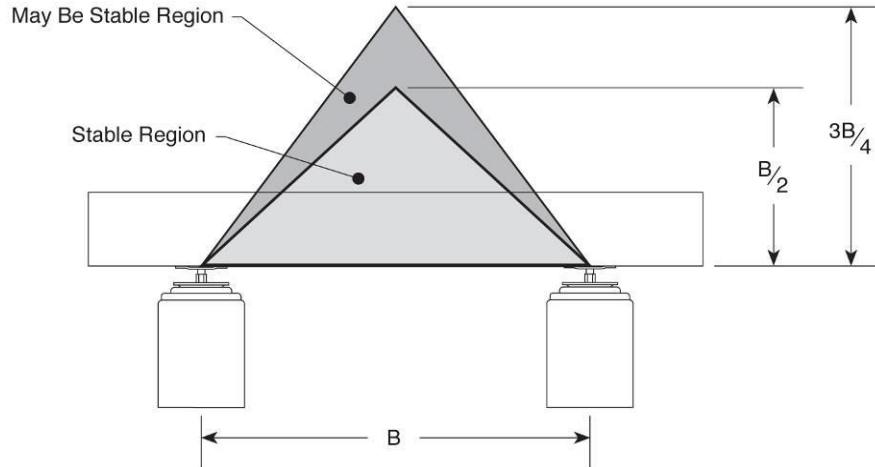

Figure 22

System stability diagram

3.2.2 Improving leveling response times

If the system is stable, the re-leveling response time may be decreased by increasing the system pressure. In addition, the needle valves may be opened until the system oscillates and then closed slightly. This is desirable if components are moving over the surface of the table.

For systems where the loads are seldom changed, slower re-leveling may be beneficial. This is accomplished by closing the needle valves slightly and/or decreasing the system pressure.

Needle valves should be opened the same amount for each master isolator that they supply, for the master-slave side valve the needle valves should be opened twice the amount to supply air to both isolators on that side.

3.2.3 Table loads and/or load positions change

If the loads are moving or changing significantly, the control arms may require adjustment. Each time the load is changed, check the relationship of the support plate to the top of each isolator. If the desired 1/4 inch is not maintained, adjust the overall system pressure and/or the sensor positions.

3.3 Maintenance

Newport Isolation Systems require little maintenance. No periodic maintenance is required.

3.3.1 Cleaning

Newport isolators are painted, powder coated, or zinc plated steel. This coated material is relatively corrosion resistant. It may be cleaned by applying non-abrasive liquid household cleaner to a rag and wiping the isolator. Avoid abrasive cleaners.

3.3.2 Air Quality

Oil, water, or debris in the air supply may contaminate the leveling valves or isolator damping system and degrade performance. Use of the Newport model ARF Air Regulator and Filter in the air supply will prevent this occurrence. The filter does require occasional cleaning.

Drain your air compressor frequently to make sure that moisture trapped inside is drained. Please refer to your air compressor manual for detailed instructions.

4 Section 4 – Troubleshooting

4.1 System Does Not Float

Use the following procedure if the system does not float, when pressure is applied to the isolators.

1. Ensure that the supply pressure is 5–10 psig (0.4–0.7 kg/cm²) above the pressure reading of any of the leveling valves. If the load is increased, the pressure should be increased to maintain the difference between supply and valve pressure. Refer to Section 1.6.
2. Check to see if all air lines are connected properly and the supply pressure is adequate (see step A). Refer to Figures 10, 11 and 12.
3. Be sure that the needle valves are not closed completely.
4. Check each leveling valve for clogging. To do this, press the control arm down. Air should flow into the isolator, accompanied by the familiar sound of moving air. Repair or replace any clogged valve. Use the ARF filter/regulator to prevent this situation.

4.2 Poor Isolation Performance

The following may lead to poor isolation performance of your system.

1. Vibration may be transmitted to the table through direct physical contact of equipment with external sources of vibration including cables.
2. Isolators that float too high, too low, or are not centered may conduct floor vibration to the table top. Centered isolators will remain centered unless the payload and isolators are moved relative to each other.
3. Equipment on the payload may be vibrating at a resonant frequency of other components. Improve the rigidity of the mounting for that equipment or remove that item from the system.
4. Air currents or pressure fluctuations may be disturbing components on the payload.

4.3 System Oscillates

If the system oscillates or “hunts”, you may have a set up with a high center of mass. Refer to the information in Section 3.2.1 or consult your Newport representative or Newport Corporation for further assistance.

4.4 System Leaks Air Constantly

All Newport isolators and valves are pressure leak tested prior to shipment. Check all tubing connections for leaks with soapy water. Tubing that is crushed out of round or that is not cut squarely may not seal in the push-in fittings. Use a single edge razor blade to cut the tubing cleanly. If testing with soapy water indicates that either the isolator or valve are leaking contact Newport Customer Service.

5 Section 5 – Factory Service

5.1 Obtaining Factory Service

To obtain information concerning factory service, contact Newport Corporation or your Newport representative. Please have the following information available.

1. Model number.
2. Purchase order number.
3. Complete description of the problem.

If components are to be returned to Newport Corporation, you will be given a Return Number, which you should reference in your shipping documents.

Please fill out the service form located on the next page, and have the information ready when contacting Newport Corporation. Include the completed service form with any parts or components that are returned.

6 Service Form

Vibration Control Products

Name

RETURN AUTHORIZATION #

Company

(Please obtain prior to return of item)

Address

Country

Date

P.O. Number

Phone Number

Item(s) Being Returned:

Model #

Serial # (or manufacturing date)

Description

Reason for return of goods (please list any specific problems)

Please Describe the Problem:

(Attach additional sheets as necessary)

Where is the Equipment Installed?

(factory, controlled laboratory, out-of-doors, etc.)

Maximum Air Pressure available?

Regulated? Yes No

Any additional information. (If special modifications have been made by the user, please describe below).

