

Vortex™ Plus TLB-6800

PRECISION FINELY TUNABLE EXTERNAL CAVITY DIODE LASER

The Vortex Plus TLB-6800 Advantage

- Magnetic damping and Star-Flex™ actuation for highest stability
- Fiber coupled option
- True mode-hop-free tuning
- Narrow linewidth

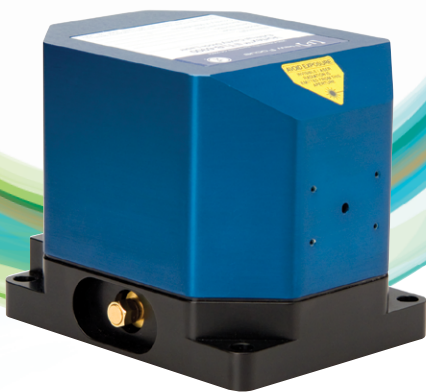

The New Focus™ tunable external cavity diode lasers deliver true continuous mode-hop-free tuning. The Vortex Plus TLB-6800 is our highest performance precision finely tunable external cavity diode laser. The Littman-Metcalf cavity configuration provides exceptional stability, piezo mode-hop-free tuning range and narrow linewidth. The Vortex Plus uses Star-Flex, a motion actuation design like no other. Thermal and finite element analyses led us to the Star-Flex design that provides stiff, reproducible rotational motion without any translation.

The Vortex Plus includes an SMA port for direct to diode high speed current modulation. When ordering, please specify the exact center wavelength (to 10 pm) in vacuum. Part number includes complete laser system and the new TLB-6800-LN laser controller. Heads and controllers can also be sold separately.

The Model TLB-6800-LN laser controller is designed to operate with either the TLB-6800 Vortex Plus Tunable Lasers or TLB-7100 Vantage® Tunable Lasers. The controller allows you to easily fine tune and adjust the output power or bias current with the press of a button or via the USB/RS-232 interface with the click of a mouse. The TLB-6800-LN controller has an easy to access front panel controls with an included output to synchronize with other devices and features a built in function generator to control piezo sweeping.

Applications

- Laser cooling
- Atomic clocks
- Spectroscopy
- Metrology
- Interferometry
- Quantum applications

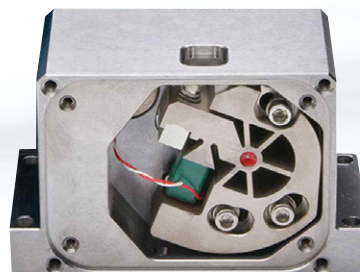

Star-Flex actuator design of the Vortex Plus laser.



TLB-6800-LN Low Noise Controller

Vortex Plus TLB-6800

Heterodyne beat note of two Vortex Plus lasers, 50 ms integration time. Deconvoluted linewidth <math><200\text{ kHz}</math>.¹

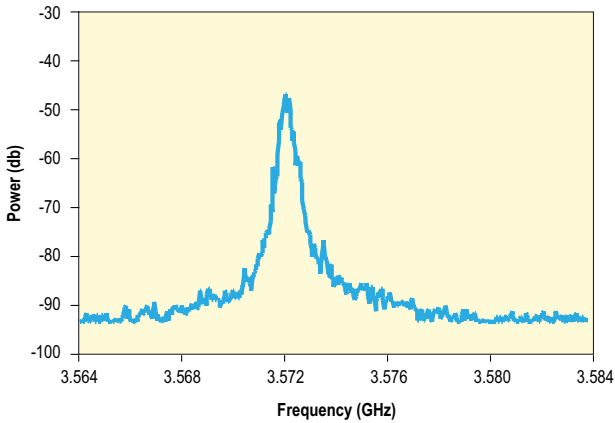

Frequency response of the Vortex Plus in comparison to the original Vortex. The Vortex Plus has improved stability due to the Star-Flex design and magnetic damping.¹

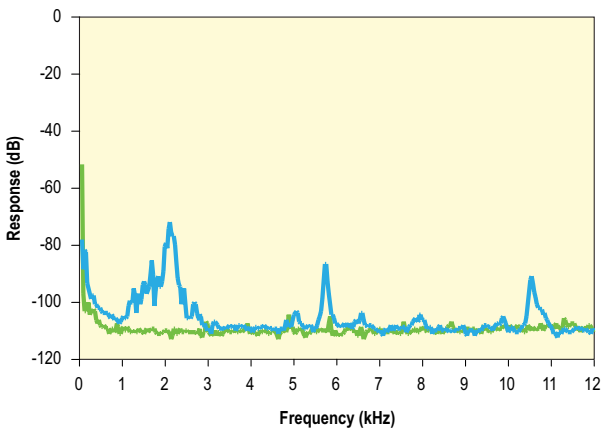

1. Typically measured performance; not a guaranteed or warranted specification.

Vortex Plus TLB-6800 Dimensions, Free Space, No Isolator

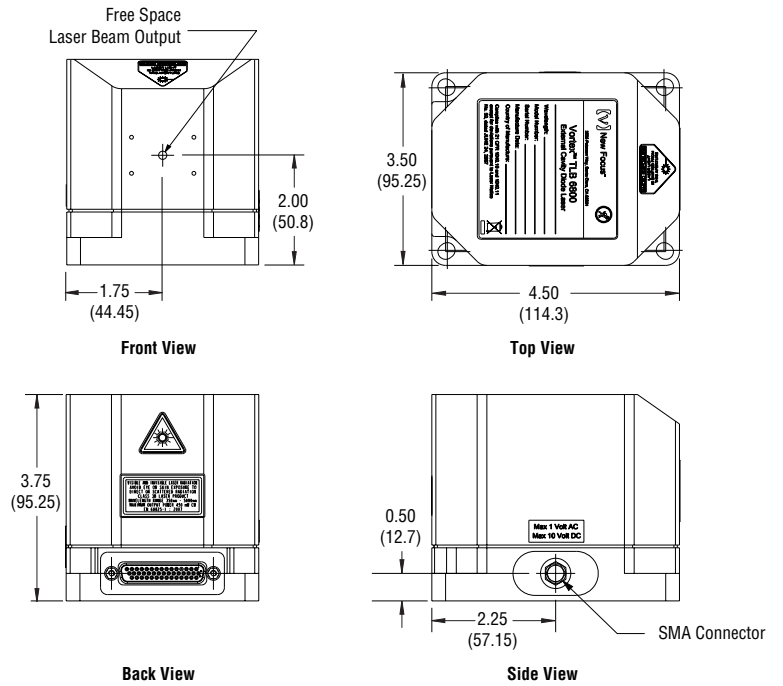

TLB-6800-LN Controller Dimensions

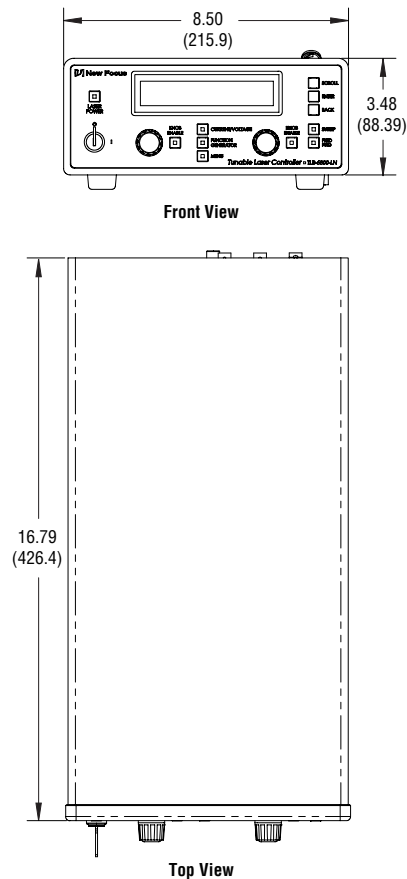

Dimensions in inch (mm)

Vortex Plus TLB-6800

Vortex Plus TLB-6800 with Fiber Dimensions

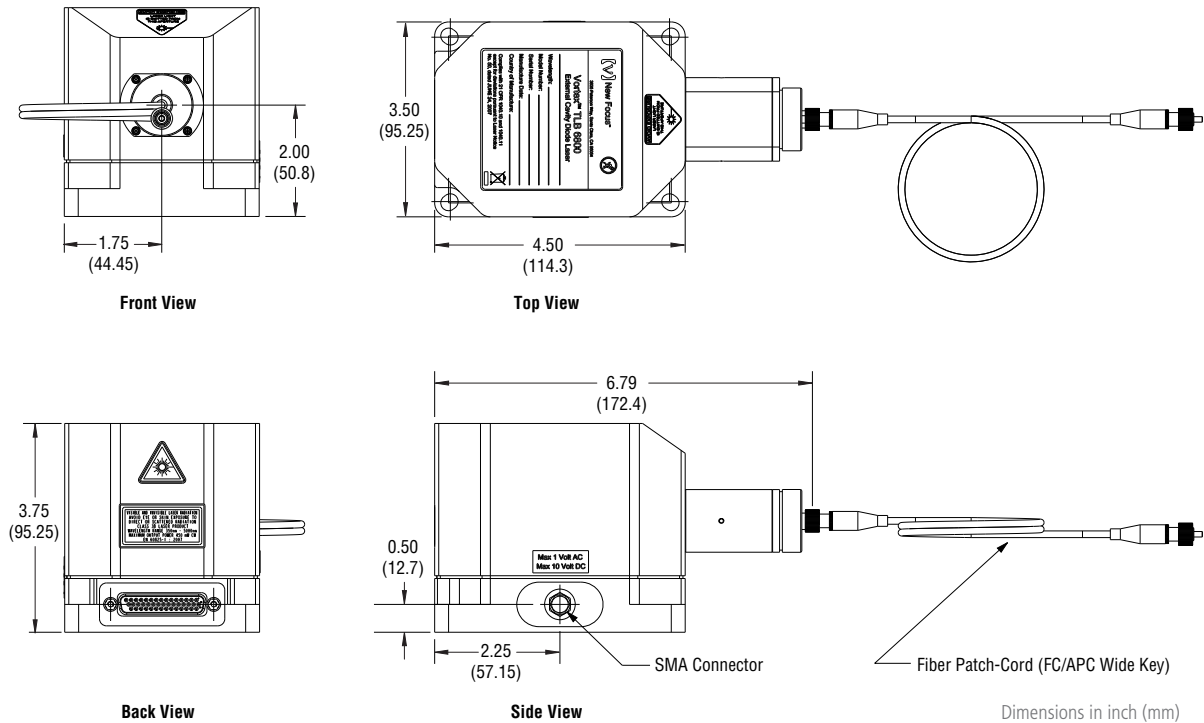

Specifications¹

	Wavelength ²	Mode-Hop Free Tuning Range	Free-Space Output Power	Fiber-Coupled Output Power
TLB-6802-455	455–457 nm	>25 GHz (20 pm)	40 mW @ 455 nm	N/A
TLB-6802	459–461 nm	>25 GHz (20 pm)	40 mW @ 461 nm	N/A
TLB-6804	632.5–640 nm	>120 GHz (160 pm)	8 mW @ 638 nm	3 mW @ 638 nm
TLB-6811	725–741 nm	>100 GHz (180 pm)	20 mW @ 737 nm	10 mW @ 737 nm
TLB-6813	765–781 nm	>100 GHz (200 pm)	70 mW @ 780 nm	35 mW @ 780 nm
TLB-6814	794–810 nm	>100 GHz (210 pm)	30 mW @ 795 nm	15 mW @ 795 nm
TLB-6817	838–853 nm	>90 GHz (220 pm)	N/A ³	15 mW @ 852 nm
TLB-6818	890–940 nm	>90 GHz (240 pm)	30 mW @ 895 nm	15 mW @ 895 nm
TLB-6820	940–990 nm	>80 GHz (250 pm)	25 mW @ 965 nm	12.5 mW @ 965 nm
TLB-6821	1030–1085 nm	>60 GHz (230 pm)	70 mW @ 1064 nm	24.5 mW @ 1064 nm
TLB-6825	1400–1490 nm	>60 GHz (400 pm)	30 mW @ 1400 nm	15 mW @ 1400 nm
TLB-6828	1520–1630 nm	>50 GHz (400 pm)	30 mW @ 1550 nm	15 mW @ 1550 nm

Vortex Plus TLB-6800

Specifications¹

	Value
Linewidth	<200 kHz (50 ms integration time)
Wavelength Stability	2 pm (over 1 hour $\pm 2^\circ\text{C}$)
Power Stability	<1% (over 1 hour $\pm 2^\circ\text{C}$)
Fine Tuning Resolution ⁴	0.01% of full PZT tuning range
Fine-Frequency Modulation Bandwidth	>100 Hz (100% amplitude) >1.5 kHz (20% amplitude)
Current Modulation Bandwidth	DC-1 MHz (through controller) 50 kHz–100 MHz (directly to diode) ⁵
Longitudinal Mode	Single
Transverse Mode	TEM ₀₀
Beam Pointing Stability	<50 μrad ($\pm 2^\circ\text{C}$)
Beam Size, typical	1–2 mm
Beam Ellipticity, typical	1:1–2:1
Polarization ⁶	Vertical
Optical Output ⁷	Free-space, optically-isolated, fiber-coupled
User Interface	Controller front panel, RS232, USB
Power Supply Requirement	100–240 VAC (50–60 Hz), power consumption <170 W
Environment Temperature, operating	15–30°C
Environment Temperature, storage	0–50°C
Environment Humidity	Non-condensing

1. Due to our continuous product improvement program, specifications are subject to change without notice.
2. Fine tuning only. Select wavelength to 0.01 nm in vacuum. Contact us for all available wavelengths.
3. Contact us for TLB-6817 free-space power.
4. Resolution is 10 mV in PZT (0.01% of full PZT tuning range) through controller front panel or command. When tuning PZT using an external voltage source through External Frequency Modulation input, resolution is dependent on voltage source.
5. Current modulation directly to diode through laser head SMA port.
6. Free space (without isolator) output is vertical linearly polarized with respect to laser head base. Output with optical isolator is 45 degrees with respect to laser head base.
7. Optically-isolated option includes an integrated 35 dB optical isolator with approximately 75% power transmission. Fiber-coupled option includes isolator and Panda-type PM fiber with FC/APC connector for laser output. Wide-type alignment key aligned with the slow axis of the PM fiber. This configuration is applicable to the input configuration for the VAMP™ tapered amplifier products. Dual stage isolation, other fiber types and connectors available upon request. Fiber couple and optically isolated options unavailable for TLB-6802-455 and TLB-6802.

Related Product



LB1005 High-Speed Servo Controller

The LB1005 High-Speed Servo Controller makes stabilizing the frequency or amplitude of lasers easy and intuitive in a one box solution. This high-speed proportional integral (P-I) controller has an intuitive front panel for the independent control of the P-I corner frequency, overall servo gain, and low-frequency gain limit.



www.spectra-physics.com

3635 Peterson Way, Santa Clara, CA 95054, USA

PHONE: 1-800-775-5273 1-408-980-4300 FAX: 1-408-980-6921 EMAIL: sales@spectra-physics.com

Belgium +32-(0)800-11 257

China +86-10-6267-0065

France +33-(0)1-60-91-68-68

Germany / Austria / Switzerland

+49-(0)6151-708-0

Japan +81-3-3794-5511

belgium@newport.com

info@spectra-physics.com.cn

france@newport.com

germany@newport.com

spectra-physics@splasers.co.jp

Korea

Netherlands

Singapore

Taiwan

United Kingdom

+82-31-8069-2401

+31-(0)30 6592111

+65-6664-0040

+886 -(0)2-2508-4977

+44-1235-432-710

korea@spectra-physics.com

netherlands@newport.com

sales.sg@newport.com

sales@newport.com.tw

uk@newport.com