

MOTION CONTROL

Our Solutions at Your Service

Over 55 years of proven performance, expertise and experience.

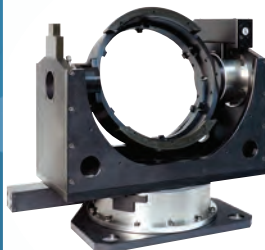
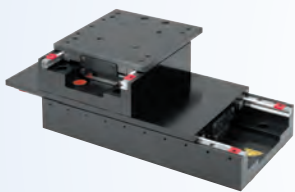
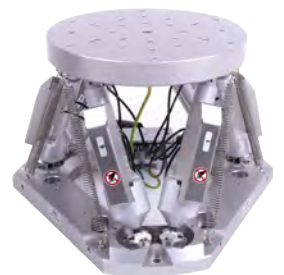

Table of Contents

About Us	3
Valued Customer	3
Global Services	5
Milestones	6
Expertise and Experience	7
Spearheading Market Development	8
Our Core Capabilities Meet Every Challenge	9
Standard Products – Simply the Best!	11
Precision Engineered Quality Linear Stages	12
Superior Rotation Stages	14
The Widest Selection of Vertical Stages	14
Optimum Performance Precision Actuators	16
Motorized Optical Mounts	17
Hexapods	18
Broadest Range of Motion Controllers	20
Application-Specific Standard Motion Products	22
Branded Products	25
Vacuum Compatible Products	26
User Friendly ESP Technology	27
Engineered Systems	28
1. Adaptations of Standard Products	28
2. Special Motion Devices	29
3. Sub-Assemblies	29
4. Advanced Customized Systems	30
OEM – Developing for the Future	31
Your Project Matters	31
Examples of OEM Products	32
Precision Actuation in Engineered OEM Sub-Systems	36
Partnering for Success – Newport’s OEM Technology Platforms	37
Air Bearing Stage Capabilities & Solutions	38
DynamYX® Family of Stages for Semiconductor Wafer Processing and Inspection	39
HybrYX™ – High-Performance Solutions for Semiconductor Wafer Inspection, Flat Panel, PCB and Photovoltaic Applications	42
SinguLYS™ – Single Axis Air Bearing Stage and Bridge	43
ZT3 Z-Tip-Tilt-Theta with Active Plane™ Technology	44
Capabilities in Advanced Ceramic Materials	45
Precision Motion Catalog	47

About Us

MKS' Newport brand is a globally recognized leader in advanced technology products and solutions for fields such as Research, Life and Health Science, Aerospace and Defense, Industrial Manufacturing, Semiconductors and Microelectronics. With decades of experience in motion control, Newport has both the capability and the capacity to provide the optimum solution for your individual needs. Our product portfolio includes standard products, special adaptations, custom systems and OEM solutions.

Valued Customer

Our Value Proposition

For over half a century, we have embraced the demands of you, our customers, around the world. We have supplied products and services to research labs, manufacturing and test environments, as well as OEM applications.

We have always listened to your needs, and as a direct result of your feedback, we are continuously investing in new products and resources in order to continue to make you successful.

We take pride in offering high-quality products and services that minimize your cost of ownership and enhance your competitive edge. We publish specifications to reflect the true performance that you expect. Every product within our extensive range is supported by a combination of proven technologies, cutting edge design elements, global and world-class manufacturing, and the highest level of customer service and technical support available in the industry.

The Newport brand's motion technologies incorporate expertise in design and manufacturing, offering you state-of-the-art products and solutions including:

- *Standard and customized motion control products*
- *Tailored products and solutions for OEMs*
- *Advanced custom multi-axis motion systems*
- *Best in class air bearing technology solutions*

This brochure provides an overview of our product offering, services, engineering and manufacturing capabilities in the field of motion. Call and let us help you.

Sincerely

Newport Motion Team

At the Cutting Edge of Research and Industry

For over 55 years, we have been a globally recognized leader in advanced technology products for research and industrial applications. We have helped researchers break through the frontiers of science and technology. By applying our innovative perspective to the manufacturing processes, we have worked with OEM's to improve their performance, their time-to-market and increase their competitive edge.

Our Newport brand plays a vital role in the following disciplines:



- Research and development
- Life & health sciences
- Aerospace, defense and security
- Industrial manufacturing
- Semiconductor wafer manufacturing
- Microelectronics applications

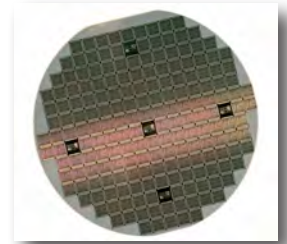

Innovation at All Times

Based on strong, solid and long-term relationships with all leading research centers, our vast industry knowledge and expertise spans a broad range of technologies. Our pledge is to continually and consistently deliver innovative products and solutions in a myriad of areas including:



- Precision positioning
- Lasers
- Optics
- Vibration control
- Spectroscopic and photonic instruments
- Light sources
- Opto-mechanics
- Customized systems



We are truly unique in combining all of these technologies and providing exceptional application knowledge for the true benefit of our customers.



Global Services

Availability at All Times

The value of the MKS corporate policy means that you will always receive the shortest lead times for our product range. Through our website, you can check pricing and lead times for the best service available.

Global Service

The MKS global infrastructure means that wherever you are, and whatever you want, we can help! At all times, we offer application support for our product selection and with one of the best after sales service organizations available, you can be assured that any issues will be instantly resolved.



Milestones

Decades of Evolutionary Expertise and World-Class Experience. Founded on Innovation – Based on Technology

The world's largest scientific research centers and leading equipment manufacturers have trusted our innovative technologies for over five decades.

60's - Laying the Foundations



The 1960s saw the beginning of Newport's history in precision positioning, when the French company, MICRO-CONTROLE S.A was founded. One of the first products was MR8.25 linear stages and TR80 rotation stages, the predecessors of the highest installed base product UMR linear stages and UTR rotation stages still produced today. This decade saw a rapid extension in the product ranges of positioning products, as well as the introduction of opto-mechanical components and optics for research and aerospace/defense applications.



70's - Introducing the First Motorized Stages



This decade witnessed the extension of the product line to motorized stages with the introduction of UT series linear stages, predecessor of the popular UTM/UTS series linear stages and the introduction of the TL17 stepper motor controller.



80's - Developing Technology Platforms

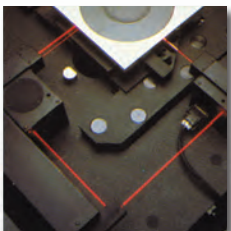

As the company evolved, so did the products, in tandem with developing advanced emerging technologies. MICRO-CONTROLE introduced the first air-bearing stages for metrology applications, as well as the FAB200, the first integrated XY air-bearing stage with 0.1 μm resolution, and the Newport PM500 high-precision motion system with crossed-roller bearings and integrated linear optical encoder feedback was introduced.

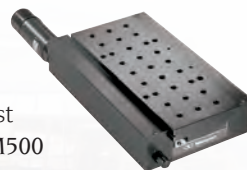

90's - Becoming a Global Leader in Motion Control

The 1990s saw us acquiring new companies to further consolidate our strong position in the marketplace. We acquired the French company MICRO-CONTROLE and with combined resources, further developed its global leadership in high precision positioning and motion control systems.



New Focus™ introduces the Picomotor™ actuator, a revolutionary motor that uses a piezoelectric transducer to turn a screw.



2000's - Continuous Innovation



With the advent of the Millennium, we take up the challenge of leveraging our expertise and experience into new market applications, pursuing our tradition of excellence and innovation. The HXP series Hexapod, an easier to use family of 6-axis parallel kinematic positioning systems, is introduced for precise control in complex motion applications demanding high load capacity and accuracy. Another product innovation took advantage of our manufacturing creativity to introduce the closed-loop version of the Agilis piezo motor product.



Oclaro's New Focus™ business is acquired, which is comprised of a portfolio of high-performance photonics products that includes opto-electronics, high-resolution actuators, opto-mechanics, tunable lasers, vacuum and ultraclean solutions, and OEM-engineered solutions.

2010's - Present - Technology Experts

Our latest development is the new DynamYX® Datum® 300 and GT, air-bearing platforms utilizing SiC technology, that are designed to handle the larger travel ranges, payloads and increased throughput requirements of next generation tools.



Expertise and Experience

Over Fifty-Five Years of Proven Performance, Expertise and Experience

Evolving in a dynamically changing research and industrial environment even prior to the founding of the company, Newport Motion has acquired a tremendous wealth of knowledge and experience second to none.

Our technologies and capabilities have constantly evolved and strengthened over the past decades. With a best-in-class R&D organization, our engineers have the necessary resources and powerful design and metrology tools to enhance product quality and deliver the best performance products and to bring new and innovative perspective to your motion control application.

Whether it is a key customized multi-axis motion for device alignment or the development of a technology solution platform to enable manufacturing of next generation semiconductor chips, or a motorized component to fit into a quality inspection system, we have the capability to adapt our expertise and experience to match your needs and to deliver the right solution. Our experts understand your business and the challenges you face every day.

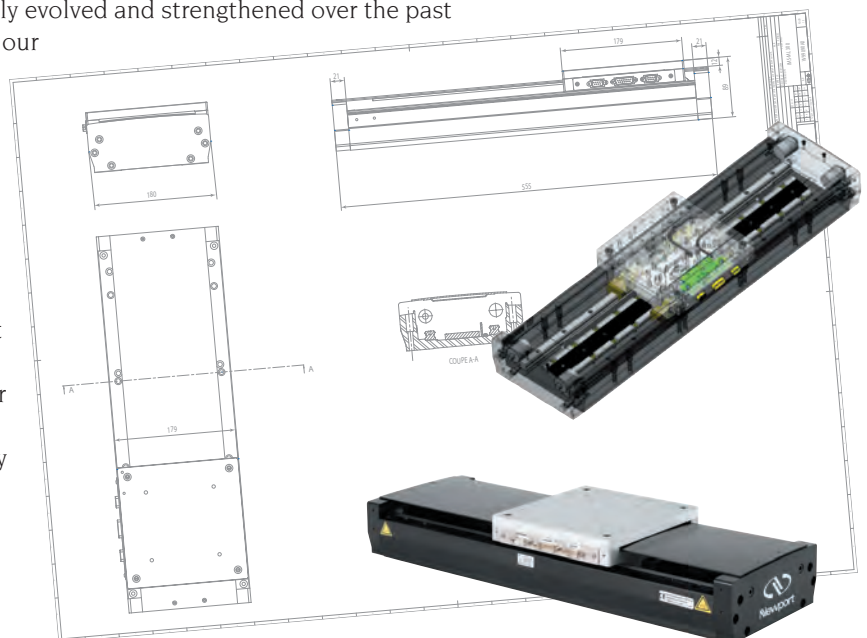

Spearheading Market Development

Our expertise and experience have led to the development of many innovative products and solutions that have spearheaded development of new markets. Today, our motion control solutions serve in a broad range of applications in multiple sectors, such as: industrial manufacturing, laser machining, aerospace and defense, fiber alignment, semiconductor wafer manufacturing, microelectronics, metrology, scientific research, life & health sciences, photovoltaics, and quality assurance.

With us you can trust your project in the hands of experts and rely on a company that keeps its promises and delivers bottom-line profits!



Laser micromachining



Microelectronics and semiconductor



Aerospace and defense



Photovoltaics



Life & health sciences

Our Core Capabilities Meet Every Challenge

Commitment to Excellence – Capacity to Deliver

With over 55 years of unprecedented experience behind us, we have both the capability and the capacity to provide the optimum solution for your individual needs. We have the most comprehensive portfolio of high precision positioning products and solutions in the industry, ranging from standard products, special adaptations and OEM solutions to subassemblies, fully engineered systems and customized OEM technology platforms. Simply tell us your application requirements and we will provide a solution.

Industry Best Products

We are justifiably proud of an extensive offering of standard linear stages, rotation stages, actuators and control electronics. These highly engineered products are not only specifically designed to meet the majority of research and industrial end-user requirements, but are the perfect solution for OEM applications.

With our standard products, you can reap the benefits of:

- *Short lead times*
- *Wide range of choices*
- *High compatibility*
- *Competitive pricing due to high-volume manufacturing*

More details about our standard product offering can be found on pages 11 to 23.

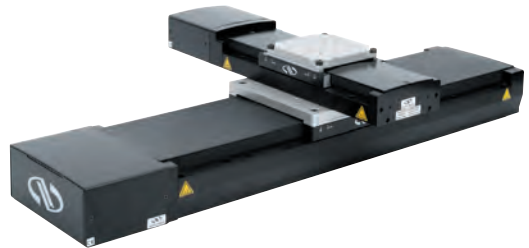

Tailor-Made Solutions

Depending on your requirements, we have the capacity to tailor a solution for you. Whether the change involves cabling, mechanical adapters, metrology or the environmental preparation of a motion component, our dedicated engineering group can deliver special requirements with the utmost precision, accuracy and efficiency.

To learn more about our special solutions, please refer to pages 24 to 25.

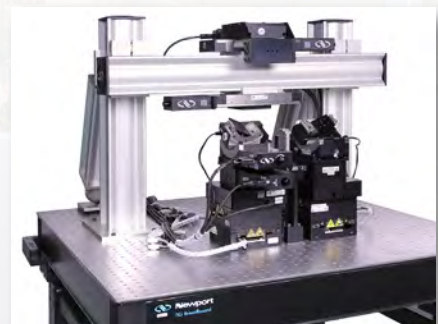
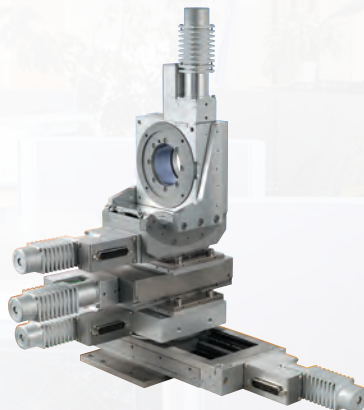

Shaping the Future with OEM's

With decades of specialized expertise and experience resulting in our recognition as a world leader in precision motion technologies, we can help you consistently achieve the next levels of performance. We are perfectly positioned to handle the positioning requirements of your current and next generation tools, through cutting edge technology and our ultimate commitment to the highest standards of quality.

To learn more about our OEM capabilities, please refer to pages 31 to 36.

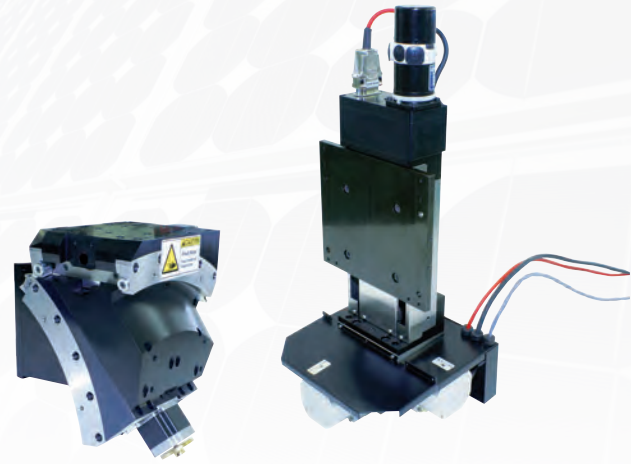

Fully Engineered Systems



Leveraging upon tremendous expertise and capability, we provide comprehensive design, engineering and manufacturing services for the design of custom motion systems to exact customer specifications. Our engineering team has the expertise in CAD design, simulation modeling and software development to design the right systems for your needs and we ensure close communication throughout the process.

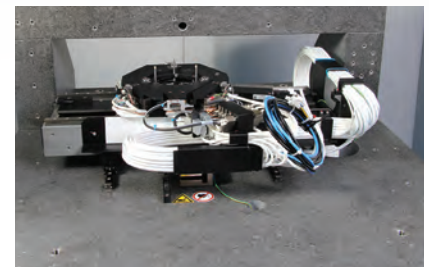

All our motion systems are backed by a worldwide dedicated team of application engineers and world-class technical support.

To learn more about our systems engineering capability, please refer to page 28-30.

Partnering for Success - Newport's customized technology platforms

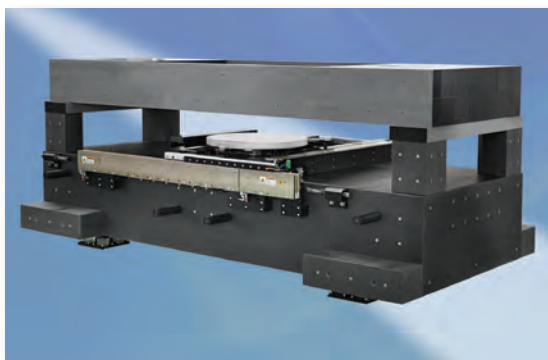

We have built upon decades of experience in motion solutions to establish the closest partnerships with clients through our customized technology platforms (CTP), specifically developed to cater to application-specific needs. These platforms have already seen massive success in partnership with OEM's in such areas as semiconductor manufacturing, laser machining, device alignment, and other industrial manufacturing processes. Other applications include flat panel display (FPD) inspection and processing, as well as laser scribing of thin-film solar panels.

CTPs are designed from leading technologies and combine the very latest in materials, manufacturing, assembly and motion control. Technologies such as air bearings, linear and rotary ball bearings, high resolution direct encoders, linear motors, piezos, flexures, ceramic materials and vibration isolation are optimally integrated into these platforms to satisfy the individual requirements of any application.

More details about our customized technology platforms can be found on pages 37 to 45.



Standard Products – Simply the Best!



Decades of Unparalleled Performance

Our extensive range of standard motion products incorporates over 55 years of specialized knowledge in precision motion control. During this time, we have provided thousands of expert solutions for hundreds of different applications in:

- Industrial manufacturing
- Fiber optic communications
- Aerospace, defense and security
- Semiconductor wafer manufacturing
- Computer peripherals
- Laser research
- Metrology
- Biomedical research

We know what matters when it comes to precision motion control. We relish opportunities in new product development, taking the full range of applications into account and thoroughly analyzing and testing our products under the most extreme conditions. That's how we can be assured that our products not only perform to their best capabilities under ideal circumstances, but will give optimum performance in your application and throughout the life of the product.

Our product range undergoes a rigorous 100% metrology control with test certificates supplied **free of charge** - the only way to ensure that every product meets or exceeds performance expectations.



Precision Engineered Quality Linear Stages

Our high precision and high performance linear stages are the best in the industry, because we know how to manufacture excellence the way that you want it! From mid to long-travel, vertical and horizontal, the Newport brand of linear stages provides the ultimate solution for the most demanding applications.

IDL-LM Series



◀ Industrial Grade, Long-Travel Linear Stages

Travel range: Up to 1200 mm
 Bi-directional repeatability: $\pm 0.1 \mu\text{m}$
 Max. speed: 2000 mm/s
 Load capacity: up to 2000 N

GTS Series



◀ High-Precision Linear Stages

Travel range: 70 or 150 mm
 Bi-directional repeatability: ± 0.06 or $\pm 0.08 \mu\text{m}$
 Max. speed: 50 mm/s
 Load capacity: 100 N

XM-S Series

Ultra-Precision, Nanometer Linear Motor Stages ▶

MIM: 1 nm
 Travel range: up to 350 mm
 Bi-directional repeatability: $0.03 \mu\text{m}$
 Max. speed: 300 mm/s
 Load capacity: 100 or 300 N



IDL165-BL Series

Industrial Grade, Mid-Travel Linear Stages ▶

Travel range: 150 or 300 mm
 Bi-directional repeatability: $\pm 1.0 \mu\text{m}$
 Max. speed: 300 mm/s
 Load capacity: 450 N



VP-25X Series

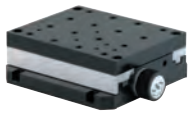

◀ Precision Compact Linear Stages

Travel range: 25 mm
 Bi-directional repeatability: ± 0.05 or $0.06 \mu\text{m}$
 Max. speed: 25 mm/s
 Load capacity: 60 N

ILS-LM-S Series

◀ High-Performance Long-Travel Linear Motor Stages

Travel range: 100, 200 or 300 mm
 Bi-directional repeatability: $\pm 0.12 \mu\text{m}$
 Max. speed: 500 mm/s
 Load capacity: 250 N



IMS-LM-S Series

High-Performance Long-Travel Linear Motor Stages ▶

Travel range: up to 1200 mm
 Bi-directional repeatability: down to $\pm 0.8 \mu\text{m}$
 Max. speed: 1000 mm/s
 Load capacity: 600 N

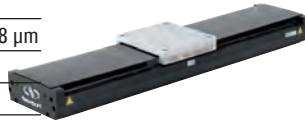

ILS Series

High-Performance Mid-Range Travel Linear Stages ▶

Travel range: up to 250 mm
 Bi-directional repeatability: down to $\pm 0.10 \mu\text{m}$
 Max. speed: 100 mm/s
 Load capacity: 250 N



IMS Series

◀ High-Performance Long-Travel Linear Stages

Travel range: up to 600 mm
 Bi-directional repeatability: ± 0.7 or $\pm 0.75 \mu\text{m}$
 Max. speed: 200 mm/s
 Load capacity: 600 N



ONE-XY Series

Integrated XY Stages ▶

Travel range: up to 290 mm
 Bi-directional repeatability: $\pm 0.040 \mu\text{m}$
 Max. speed: 200 mm/s
 Load capacity: up to 350 N



Delay Line Series

Optical Delay Line Stages ▶

Travel range: 125, 225, 325 mm

Bi-directional repeatability: $\pm 0.15 \mu\text{m}$

Max. speed: 500 mm/s



MTN Series



◀ Long-Travel Steel Linear Stages

Travel range: 100, 200 or 300 mm

Bi-directional repeatability: ± 0.75 or $\pm 1.75 \mu\text{m}$

Max. speed: 40 or 100 mm/s

Load capacity: 1000 N

FCL Series

Intelligent Stepper Motor Linear Stages ▶

Travel range: 50, 100, 200 mm

Bi-directional repeatability: ± 2.25 or $\pm 2.5 \mu\text{m}$

Max. speed: 20 mm/s

Load capacity: 250 N



MTN-BLHS Series



◀ Long-Travel Steel Linear Stages

Travel range: 100, 200 or 300 mm

Bi-directional repeatability: $\pm 0.3 \mu\text{m}$

Max. speed: 250 mm/s

Load capacity: 1000 N

UTS Series



◀ Mid-Range Travel Steel Linear Stages

Travel range: 50, 100 or 150 mm

Bi-directional repeatability: ± 2.3 or $\pm 0.8 \mu\text{m}$

Max. speed: 20 or 40 mm/s

Load capacity: 200 N

MFA Series

Miniature Linear Stages ▶

Travel range: 25 mm

Bi-directional repeatability: $\pm 0.15 \mu\text{m}$

Max. speed: 2.5 mm/s

Load capacity: 50 N



Agilis™ – AG-LS25

Piezo Motor Driven Linear Stages ▶

Travel range: 12 or 27 mm

Min. incremental motion: 0.5 or 0.1 μm

Max. speed: $> 0.5 \text{ mm/s}$

Load capacity: 3 N



NPX Series



◀ NanoPositioning Linear Stages

Travel range: 100, 200 or 400 μm

Resolution: 0.4 or 4 nm

Load capacity: up to 100 N

CONEX-SAG-LC



◀ Super Agilis Piezo Stage with CONEX Controller

Travel range: 16, 32 or 48 mm

Min. incremental motion: 25 or 100 nm

Max. speed: $> 10 \text{ mm/s}$

Load capacity: 20 or 30 N

Picomotor™ Stages

Integrated Motion Control Solutions ▶

Travel range: 13 or 25 mm

Max. speed: 0.02 mm/s

Load capacity: 13 N



CONEX-MFA-CC



◀ MFA-CC Stage with CONEX-CC Controller

Travel range: 25 mm

Bi-directional repeatability: $\pm 0.15 \mu\text{m}$

Max. speed: 2.5 mm/s

Load capacity: 50 N

The Widest Selection of Vertical Stages

GTS Family



◀ High-Precision Long Travel Lift Stages

Travel range: 30 or 70 mm

Bi-directional repeatability: $\pm 0.1, 0.2$ or $0.5 \mu\text{m}$

Max. speed: 10 or 5 mm/s

Load capacity: 40 or 70 N

VP-5ZA

▶ High-Precision Low Profile Lift Stage

Travel range: 4.8 mm

Bi-directional repeatability: $\pm 0.1 \mu\text{m}$

Max. speed: 5 mm/s

Load capacity: 50 N



UZS80 Series

◀ Compact Steel Lift stages

Travel range: 4.5 mm

Bi-directional repeatability: ± 0.4 or $\pm 0.5 \mu\text{m}$

Max. speed: 2 or 4 mm/s

Load capacity: 30 N



IMS-V Series

▶ High-Load Long Travel Vertical Stages

Travel range: 100 or 300 mm

Bi-directional repeatability: ± 0.15 or $\pm 0.2 \mu\text{m}$

Max. speed: 20 mm/s

Load capacity: 400 N



ZVR Series



◀ Integrated Vertical and Rotation Stages

Travel range: 10 mm and 360°

Bi-directional repeatability: $\pm 1.2 \mu\text{m}$ and $\pm 0.0013^\circ (\pm 0.003^\circ)$

Max. speed: 10 mm/s and $40^\circ/\text{sec}$ ($80^\circ/\text{sec}$)

Load capacity: 100 N

XMS-V Series

▶ Direct Drive, Ultra Precision Stages

Travel range: 50 or 100 mm

Bi-directional repeatability: $\pm 0.05 \mu\text{m}$

Max. speed: 300 mm/s

Load capacity: 100 N



Superior Rotation Stages

Newport's reputation for rotation stages is unsurpassed. High speed, superior reliability, positioning accuracy – we design our rotation stages to offer the optimum in flexibility and size.

RV Series

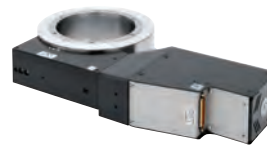

◀ High-Performance Precision Rotation Stages

Bi-directional repeatability: ± 0.0004 or $\pm 0.0006^\circ$

Max. speed: up to $80^\circ/\text{s}$

Wobble: $\pm 4, \pm 5$ or $\pm 8 \mu\text{rad}$

Load capacity: up to 6500 N

RGV-S Series



◀ High-Speed Precision Rotation Stage

Bi-directional repeatability: $\pm 0.00015^\circ$

Max. speed: 720 or $1000^\circ/\text{s}$

Wobble: ± 5.0 or $\pm 7.0 \mu\text{rad}$

Load capacity: 100 or 2700 N

URB100CC

▶ Belt Drive Rotation Stage

Bi-directional repeatability: $\pm 0.015^\circ$

Max. speed: $720^\circ/\text{s}$

Wobble: $\pm 15 \mu\text{rad}$

Load capacity: 100 N

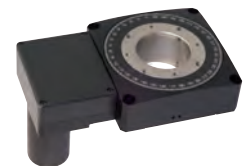

URS Series

Precision Rotation Stages ▶

Bi-directional repeatability: ± 0.0014 or 0.0044°

Max. speed: 40 or 80 $^\circ/s$

Wobble: $\pm 12 \mu rad$

Load capacity: 100, 200 or 300 N



BG Series



◀ Goniometric Cradles

Travel range: up to $\pm 45^\circ$

Bi-directional repeatability: down to $\pm 0.0015^\circ$

Max. speed: up to 20 $^\circ/s$

Load capacity: up to 500 N

SR50 & PR50 Series



◀ Compact Rotation Stages

Bi-directional repeatability: ± 0.015 or $\pm 0.030^\circ$

Max. speed: 4 or 20 $^\circ/s$

Wobble: $\pm 20 \mu rad$

Load capacity: 30 or 10 N

Agilis™ – AG-PR100

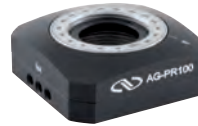

◀ Piezo Motor Driven Rotation Stage

Travel range: 360° , continuous

Min. incremental motion: $5 \mu rad$ (1 arc-sec)

Max. speed: 2 $^\circ/s$

Load capacity: 2 N

8410

Picomotor Rotary Stage ▶

Resolution: 0.2 mrad

Max. speed: 1-2 $^\circ/s$

Load capacity: 5 N



CONEX-URS50BCC

URS50BCC Stage with CONEX-CC Controller ▶

Bi-directional repeatability: $\pm 0.0005^\circ$

Max. speed: 20 $^\circ/s$

Wobble: $\pm 12.5 \mu rad$

Load capacity: 100 N



CONEX-SR50CC & CONEX-PR50CC

◀ SR50CC or PR50CC Stage with CONEX-CC Controller

Bi-directional repeatability: ± 0.015 or $\pm 0.030^\circ$

Max. speed: 4 or 20 $^\circ/s$

Wobble: $\pm 20 \mu rad$

Load capacity: 30 or 10 N



CONEX-AG-GON-xP Series

◀ AG-GON-xP Goniometers with CONEX-AGP Controller

Travel range: $\pm 5.5^\circ$ or $\pm 7.5^\circ$

Uni-directional repeatability: 0.00064° or 0.0005°

Max. speed: 0.33 or 0.45 $^\circ/s$

Load capacity: 3.5 N



CONEX-BGS50CC

BGS50CC Goniometric Cradle with CONEX-CC Controller ▶

Travel range: up to $\pm 30^\circ$

Bi-directional repeatability: $\pm 0.065^\circ$

Max. speed: 10 $^\circ/s$

Load capacity: 20 N



Optimum Performance Precision Actuators

Our high speed, state-of-the-art actuators are designed for a purpose – combining high precision with compactness and accuracy every time. Nothing competes with the Newport product range.

VP-25AA

High-Precision Actuator ▶

Travel range: 25 mm
Bi-directional repeatability: $\pm 0.2 \mu\text{m}$
Max. speed: 25 mm/s
Load capacity: 40 N



TRB Series

Compact Actuators ▶

Travel range: 6, 12, 25 mm
Bi-directional repeatability: ± 0.13 or $\pm 0.15 \mu\text{m}$
Max. speed: 0.3 or 4 mm/s
Load capacity: 90 N



TRA Series

Compact Actuators ▶

Travel range: 6, 12, 25 mm
Bi-directional repeatability: ± 0.15 or $\pm 0.18 \mu\text{m}$
Max. speed: 0.2 or 0.4 mm/s
Load capacity: 60 N



Picomotor™

◀ Piezo Motor Actuators

<30 nm resolution in a compact design
Set-and-forget long-term stability-
these actuators stay put
Vacuum and ultra high vacuum
versions available



NPA Series



◀ NanoPositioning Piezo Actuators

Travel range: 25, 50, 100 μm
Resolution: 0.05, 0.1, 0.2 nm
Repeatability: 16, 20, 28 nm
Load capacity: 1000 N

NPM140

Piezoelectric Micrometer Adapter ▶

Travel range: 140 μm
Resolution: 0.1 nm
Repeatability: 35 nm
Load capacity: 100 N



LTA Series



◀ Precision Long Travel Actuators

Travel range: 25 or 50 mm
Bi-directional repeatability: $\pm 0.3 \mu\text{m}$
Max. speed: 1 or 5 mm/s
Load capacity: 120 or 50 N

8311 Picomotor

Piezoelectric Micrometer Adapter ▶

Travel range: 12.7 mm
Min. Incremental Motion: <30 nm
Max. speed: 1.2 mm/min
Axial Load Capacity: 22 N



CONEX-LTA-HL & CONEX-LTA-HS

LTA Precision Long Travel Actuator with CONEX-CC Controller ▶

Travel range: 25 or 50 mm
Bi-directional repeatability: $\pm 0.3 \mu\text{m}$
Max. speed: 1 or 5 mm/s
Load capacity: 120 or 50 N



CONEX-TRAxCC

◀ TRA Precision Long Travel Actuator with CONEX-CC Controller

Travel range: 6, 12, 25 mm
Bi-directional repeatability: 4 μm
Max. speed: 0.4 mm/s
Load capacity: 60 N



CONEX-NSA12

◀ Miniature Actuator with CONEX-PP Controller

Travel range: 11 mm
Bi-directional repeatability: $\pm 5.0 \mu\text{m}$
Max. speed: 0.9 mm/s
Load capacity: 28 N



CONEX-TRBxxCC

Piezoelectric Micrometer Adapter ▶

Travel range: 6, 12, 25 mm
Bi-directional Repeatability: $\pm 0.75 \mu\text{m}$
Max. speed: 2 mm/s
Load capacity: 90 N



Motorized Optical Mounts

The Newport brand offers a large selection of motorized optical mounts for any research or laboratory need.

FSM-300

Fast Steering Mirrors ▶

Number of axes: 2 (tip-tilt)
 Angular range: ± 26 mrad, mechanical
 Resolution: ≤ 1 μ rad rms, typical
 Repeatability: ≤ 3 μ rad rms, mechanical



PSM2

◀ Ultra-Fast Piezo Steering Mirror

Angular range: 1.6–2 mrad
 Travel range: 12–16 μ m
 Angular resolution: 0.004–0.04 μ rad
 Linear resolution: 0.03–3 nm



Agilis™

Compact Piezo Driven Optical Mount ▶

Optic diameter: 0.5" and 1.0"
 Angular Range: $\pm 2^\circ$
 Adjustment sensitivity: 1–2 μ rad
 Max. speed: 0.75 $^\circ$ /s



NPO140 & NPO250

Nanofocusing Objective Stages ▶

Travel range: 140 μ m or 250 μ m
 Resolution: 0.3 nm or 0.5 nm
 Repeatability: 30 or 46 nm
 Max. lens weight: 500 g



Picomotor™



◀ Motorized Optical Mounts

Optic diameter: 0.5", 1.0" and 2.0"
 Motorized axes: 2 or 3
 Angular resolution: 0.7 μ rad
 Angular range: $\pm 4^\circ$

A typical example of mounting a motorized actuator to other Newport manual products, TRA actuators are mounted on a SN100 SUPREMA™ mirror mount. Generally, actuators are designed to be mounted on larger mirror mounts or manual stages.



Resolution: 5 μ rad
 Travel: $\pm 7^\circ$
 Speed: 0.57 $^\circ$ /s

◀ SUPREMA™ optical mount with TRA compact actuators.

Please contact our inside sales team or refer to newport.com for compatibility guides.

Hexapods

A Hexapod is a parallel kinematic motion device that provides six degrees of freedom: X, Y, Z, pitch, roll, and yaw. Hexapods are effective solutions to complex motion applications that demand high load capacity and accuracy in up to six independent axes.



HXP50's

	HXP50-MECA						HXP50V6-MECA					
	X	Y	Z	Θx	Θy	Θz	X	Y	Z	Θx	Θy	Θz
Travel range ⁽¹⁾	±17 mm	±15 mm	±7 mm	±9°	±8.5°	±18°	±17 mm	±15 mm	±7 mm	±9°	±8.5°	±18°
MIM, Minimum incremental motion	0.1 μm	0.1 μm	0.05 μm	0.05 mdeg	0.05 mdeg	0.1 mdeg	0.8 μm ⁽⁶⁾	0.8 μm ⁽⁶⁾	0.4 μm ⁽⁶⁾	0.4 mdeg ⁽⁶⁾	0.4 mdeg ⁽⁶⁾	0.8 mdeg ^{(6)±}
Uni-directional repeatability, typical	±0.1 μm	±0.1 μm	±0.05 μm	±0.05 mdeg	±0.05 mdeg	±0.1 mdeg	±0.2 μm	±0.2 μm	±0.1 μm	±0.4 mdeg	±0.4 mdeg	±0.2 mdeg
Bi-directional repeatability, typical ⁽²⁾	±0.6 μm	±0.6 μm	±0.3 μm	±0.3 mdeg	±0.3 mdeg	±0.6 mdeg	±1.0 μm	±1.0 μm	±0.15 μm	±0.15 mdeg	±0.15 mdeg	±0.3 mdeg
Max. speed	14 mm/s	12 mm/s	5 mm/s	6 °/s	6 °/s	15 °/s	2 mm/s	1.9 mm/s	0.8 mm/s	2.4 °/s	2.4 °/s	6 °/s
Stiffness ⁽³⁾	2 N/μm	2 N/μm	25 N/μm	–	–	–	2 N/μm	2 N/μm	25 N/μm	–	–	–
Centered load capacity ⁽⁴⁾	50 N						50 N					

¹⁾ Travel ranges are interdependent. The listed values are max. travels per axis when all other axis are in their centered position.

²⁾ With standard setting (with hysteresis compensation).

³⁾ Stiffness depends on Hexapod position. Values are given for all axis in their centered position.

⁴⁾ See graphs on next page for maximum payload height and cantilever distance.

⁵⁾ Vacuum version to 10⁻⁶ hPa.

⁶⁾ Values in Open-loop/Closed-loop.



Guaranteed Specifications

	HXP50HA-MECA		
	X	Y	Z
Uni-directional repeatability	±0.15 μm	±0.15 μm	±0.075 μm
Bi-directional repeatability	±1.5 μm	±1.5 μm	±1.25 μm
Absolute Accuracy	±5 μm	±5 μm	±2.5 μm
Pitch	±50 μrad	±50 μrad	±25 μrad
Yaw	±50 μrad	±50 μrad	±25 μrad



HXP200

	HXP200						HXP200-S					
	X	Y	Z	Θx	Θy	Θz	X	Y	Z	Θx	Θy	Θz
Travel range ⁽¹⁾	59 mm	±54 mm	±25 mm	±15°	±14.5°	±30°	±40 mm	±45 mm	±27 mm	±9°	±8°	±15°
MIM, Minimum incremental motion	0.2 μm	0.2 μm	0.1 μm	0.1 mdeg	0.1 mdeg	0.2 mdeg	0.15μm	0.15μm	0.15μm	0.1mdeg	0.1mdeg	0.1mdeg
Uni-directional repeatability, typical	±0.125 μm	±0.125 μm	±0.1 μm	±0.1 mdeg	±0.1 mdeg	±0.125 mdeg	±0.1 μm	±0.1 μm	±0.1 μm	±0.1 mdeg	±0.1 mdeg	±0.1 mdeg
Max. speed	81 mm/s	70 mm/s	26 mm/s	16 °/s	15 °/s	41 °/s	81 mm/s	70 mm/s	26 mm/s	16 °/s	15 °/s	41 °/s
Stiffness	3 N/μm	3 N/μm	40 N/μm	–	–	–	3 N/μm	3 N/μm	40 N/μm	–	–	–
Centered Load Capacity	500 N						850N					

¹⁾ 59 mm ±54 mm ±25 mm ±15° ±14.5° ±30°

HXP1000

	X	Y	Z	Θx	Θy	Θz
Travel range ⁽¹⁾	-62; +93 mm	±69 mm	±39.5 mm	±11°	±10°	±19.5°
MIM, Minimum incremental motion	0.3 μm	0.3 μm	0.16 μm	0.06 mdeg	0.06 mdeg	0.1 mdeg
Uni-directional repeatability, typical	±0.15 μm	±0.15 μm	±0.08 μm	±0.03 mdeg	±0.03 mdeg	±0.05 mdeg
Max. speed	9 mm/s	9 mm/s	4 mm/s	1.4 °/s	1.4 °/s	2.8 °/s
Stiffness ⁽²⁾	10 N/μm	10 N/μm	100 N/μm	–	–	–
Centered Load Capacity	4500 N					

¹⁾ Travel ranges are interdependent. The listed values are max. travels per axis when all other axis are in their centered position (Height = 395 mm for Z).

²⁾ Stiffness depends on Hexapod position. Values are given for all axis in their centered position.



HXP100's



	HXP100-MECA						HXP100V6-MECA ⁽⁴⁾					
	X	Y	Z	Θ _x	Θ _y	Θ _z	X	Y	Z	Θ _x	Θ _y	Θ _z
Travel range ⁽¹⁾	±27.5 mm	±25 mm	±14 mm	±11.5°	±10.5°	±19°	±27.5 mm	±25 mm	±14 mm	±11.5°	±10.5°	±19°
MIM, Minimum incremental motion	0.5 μm	0.5 μm	0.25 μm	0.25 mdeg	0.25 mdeg	0.5 mdeg	0.5 μm	0.5 μm	0.25 μm	0.25 mdeg	0.25 mdeg	0.5 mdeg
Uni-directional repeatability, typical	±0.25 μm	±0.25 μm	±0.125 μm	±0.215 mdeg	±0.125 mdeg	±0.25 mdeg	±0.5 μm	±0.5 μm	±0.5 μm	±0.025 mdeg	±0.025 mdeg	±0.025 mdeg
Bi-directional repeatability ⁽²⁾ , typical	±2.0 μm	±2.0 μm	±1.0 μm	±1 mdeg	±1 mdeg	±2 mdeg	±2.5 μm	±2.5 μm	±1.5 μm	±1.25 mdeg	±1.25 mdeg	±2.5 mdeg
Max. speed	2.5 mm/s	2 mm/s	1 mm/s	1.8 °/s	1.7 °/s	3 °/s	0.5 mm/s	0.5 mm/s	0.25 mm/s	0.2 °/s	0.2 °/s	0.4 °/s
Stiffness	5 N/μm	5 N/μm	40 N/μm	–	–	–	5 N/μm	5 N/μm	5 N/μm	–	–	–
Centered load capacity ⁽³⁾	200 N						200 N					

	HXP100P-MECA					
	X	Y	Z	Θ _x	Θ _y	Θ _z
Travel range ⁽¹⁾	±27.5 mm	±25 mm	±14 mm	±11.5°	±10.5°	±19°
MIM, Minimum incremental motion	0.1 μm	0.1 μm	0.05 μm	0.05 mdeg	0.05 mdeg	0.1 mdeg
Uni-directional repeatability, typical	±0.1 μm	±0.1 μm	±0.05 μm	±0.05 mdeg	±0.05 mdeg	±0.1 mdeg
Bi-directional repeatability ⁽²⁾ , typical	±0.25 μm	±0.25 μm	±0.125 μm	±0.125 mdeg	±0.125 mdeg	±0.25 mdeg
Max. speed	12 mm/s	10 mm/s	5 mm/s	8 °/s	8 °/s	16 °/s
Stiffness	3 N/μm	3 N/μm	24 N/μm	–	–	–
Centered load capacity ⁽³⁾	60 N					

¹⁾ Travel ranges are interdependent. The listed values are max. travels per axis when all other axis are in their centered position.
²⁾ With standard compensation (with hysteresis compensation).
³⁾ For allowable cantilevered loads, see Max. Cantilever Distance of the Load below.
⁴⁾ Vacuum version to 10⁻⁶ hPa.

HexaViz Software

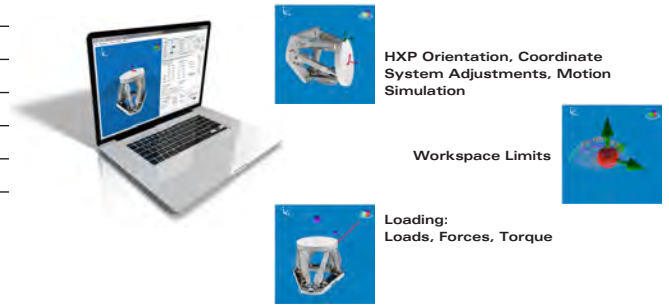

Work and Tool Coordinate Systems

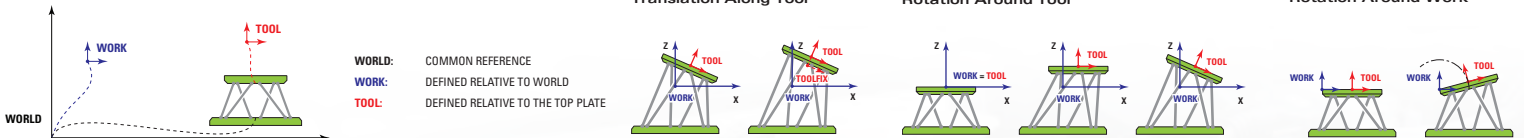

Guaranteed Specifications



	HXP100HA-MECA			HXP100PHA-MECA		
	X	Y	Z	X	Y	Z
Uni-directional repeatability	±0.25 μm	±0.25 μm	±0.125 μm	±0.15 μm	±0.15 μm	±0.075 μm
Bi-directional repeatability	±3 μm	±3 μm	±2 μm	±0.5 μm	±0.5 μm	±0.25 μm
Accuracy	±10 μm	±10 μm	±5 μm	±5 μm	±5 μm	±2.5 μm
Pitch	±75 μrad	±75 μrad	±75 μrad	±37.5 μrad	±37.5 μrad	±37.5 μrad
Yaw	±75 μrad	±75 μrad	±75 μrad	±37 μrad	±37 μrad	±37 μrad

Hexapod Trajectory

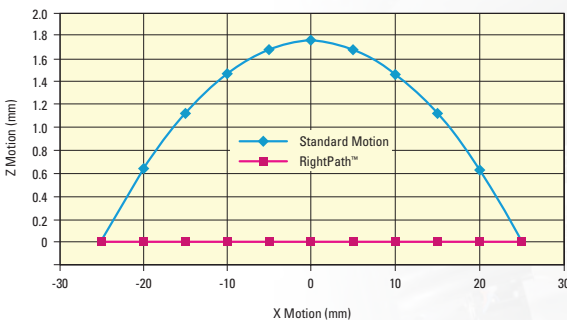

RightPath™ Trajectory Control

RightPath™ Trajectory Control is a firmware feature that enables scanning motion along a defined trajectory, line, arc or rotation, with minimal runout and at a constant, definable speed.

Broadest Range of Motion Controllers

We deliver solutions with our advanced range of motion electronics, offering the most advanced motion controllers and drivers available in the world. Whatever your requirements, our product range covers every requirement with precision, accuracy and optimum performance.

XPS-D



◀ Universal High-Performance Motion Controller

- 1-8 axes universal motion controller
- High-speed 10/100/1000 Base-T Ethernet TCP/IP communication
- Up to 20 kHz servo loop with advanced variable PID's
- Wide variety of motion modes from basic to complex PVT trajectories
- Extensive Analog and Digital I/O Capability
- High speed up to 4-Axis PCO

XPS-RL-D

Universal Controller, High Performance ▶

- Integrated 1-4 axes motion controller/driver for stepper, DC servos, brushless motors, piezos, voice coils, and other motion devices
- High-speed 10/100/1000 Ethernet TCP/IP communication
- Wide variety of motion modes, trajectories and compensations
- Advanced servo loop and filter functions
- Basic or Extended I/O, PCO, triggers and synchronization capabilities



ESP302

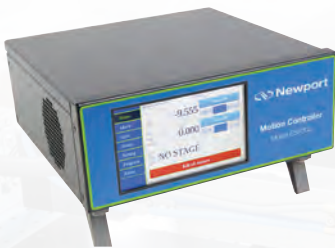

◀ The Most User-Friendly and Versatile Motion Controller in the World

- 1 to 3 axis motion controller for stepper or DC motors
- Ethernet, RS232 communication interface
- Synchronized pt to pt, 3D Linear and 2D circular interpolation, Master-slave, Electronic Gathering
- ESP stage detection
- Touch screen LCD display

SMC100

Inexpensive and Compact Single-Axis Motion Controller/Driver ▶

- For DC-servo and stepper motors up to 48 V_{DC} and 1.5 Arms
- Internal RS-485 link allows networking up to 31 controllers
- Convenient multi-axis programming
- Advanced backlash and Hysteresis compensation mode
- Enhanced system safety by reading parameters from Newport ESP compatible stages



PZC200



◀ NanoPZ Controller

High reliable operation with 30 nm motion sensitivity over 12.5 mm travel

10x faster speed (>0.2 mm/s)

No loss of position with removal of power; ideal for set-and-forget applications

8742-8743-CL

Picomotor Controller/Driver ▶

Integrated 1–4 axes motion controller/driver for picomotors

Advanced 10/100 Ethernet paired with either plug-and-play USB 2.0 or USB 2.0 and RS-485 communication

Advanced picomotor auto detection

Embedded dynamic HTTP server



NPC3/NPC3SG



◀ 3-channel Piezo Amplifier

Compact, 3-channel piezoelectric amplifier

Manual, analog and computer control

RS232 and USB interface

Low-noise voltage output (0.3 mV rms@500 Hz)

Agilis™ AG-UC2 & AG-UC8

Agilis™ Series Controllers ▶

Compatible with all Agilis piezo motor-driven products

Available in: 2-channel hand-held AG-UC2 or the 8-channel AG-UC8, both with USB interface

Available in the 8-channel AG-UC8PC, with USB, RS232 and RS485 interfaces

ASCII commands, DLL's and LabView VI's included

Optional USB power supply

NPC100USB



◀ NPC100USB

Single axis

USB interface

Compact

Application-Specific Standard Motion Products

Metrology



The CONEX-LDS electronic autocollimator performs high resolution angular measurements for alignment, quality assurance, and metrology applications. Featuring a highly collimated, 670 nm laser diode, the CONEX-LDS allows for non-contact measurements over long working distances of up to 5 meters.

◀ CONEX-LDS Electronic Autocollimator with Integrated Controller

Sensitivity	0.01 μ rad
Beam diameter	22.5 mm
Beam divergence	100 μ rad
Data acquisition	2000 Hz
Measurement range	5 m μ W
Wavelength	670 nm
Operating temperature range	+15 to +25 $^{\circ}$ C
Controller includes USB, RS-422, Ethernet and analog outputs	

Optical Delay Line Kit - DL Series

The Newport DL Delay Line Kits provide scientists and researchers with all the necessary components to build an optical delay line. The selection of proven Newport components has been thoroughly tested to provide a maximum of performance and flexibility. Newport Delay Line Kits are a convenient and economic solution for a wide range of applications where the delay between two or more light pulses needs to be varied by increments in the femtosecond to nanosecond regime.

All Newport Delay Line Kits come with two Suprema[®] Series steel mirror mounts. These high quality mirror mounts play a key role in assuring the required long-term stability over the whole duration of an experiment. The Delay Line Kits also contain a number of iris apertures to facilitate the precise alignment of the laser beam to the delay line. An additional Suprema mount for reflecting the beam back to the experiment is also included.

SPECIFICATIONS

	DL125	DL225	DL325
Travel Range	125 mm	225 mm	325 mm
Max. Speed	500 mm/s	500 mm/s	500 mm/s
Min. Incremental Motion	75 nm	75 nm	75 nm
Max. Acceleration	7500 mm/s ²	7500 mm/s ²	7500 mm/s ²
Accuracy, Guaranteed	\pm 1.5 μ m	\pm 2.0 μ m	\pm 2.5 μ m
Bi-directional Repeatability	\pm 0.15 μ m	\pm 0.15 μ m	\pm 0.15 μ m



MODEL P/N

DESCRIPTION

DL-BKIT19M	Optical Delay Line Kit, Single Pass, 9848 Retroreflector, metric
DL-BKIT1U-S-M	Optical Delay Line Kit, Single Pass, Silver UBBR Retroreflector, metric
DL-BKIT1U-UV-M	Optical Delay Line Kit, Single Pass, UV UBBR Retroreflector, metric
DL-BKIT2U-S-M	Optical Delay Line Kit, Double Pass, Silver UBBR Retroreflector, metric
DL-BKIT2U-UV-M	Optical Delay Line Kit, Double Pass, UV UBBR Retroreflector, metric
DL-BKIT4U-S-M	Optical Delay Line Kit, Quadruple Pass, Silver UBBR retroreflector, metric
DL-BKIT4U-UV-M	Optical Delay Line Kit, Quadruple Pass, UV UBBR retroreflector, metric

Beam Stabilization

GuideStar™ II Laser Beam Steering Correction System ►

- Integrated controller/driver for 4-axis active beam-stabilization
- Auto-configuration for easy setup
- Compatible with CW or pulsed lasers operations
- Easily connects to standard motorized mirrors and beam-position detectors



Paired with the New Focus™ position-sensing detectors and the Picomotor™ actuated motorized mirror mounts, the GuideStar™ II Controller provides high-precision compensation for laser pointing and position drift.

Alternatively, a modular beam stabilization solution is available with Agilis series mirror mount, CONEX-PSD9 position sensing detector and CONEX-TRA series actuators.

For higher dynamic beam stabilization, refer to the Fast Steering Mirror, FMS-300.



Sensor Testing with Gimbal Systems

We offer simple half (HG) and full (FG) gimbals based on standard rotary stage offerings, designed for sensor testing and calibration applications.



Laser Micromachining Software (LMS)

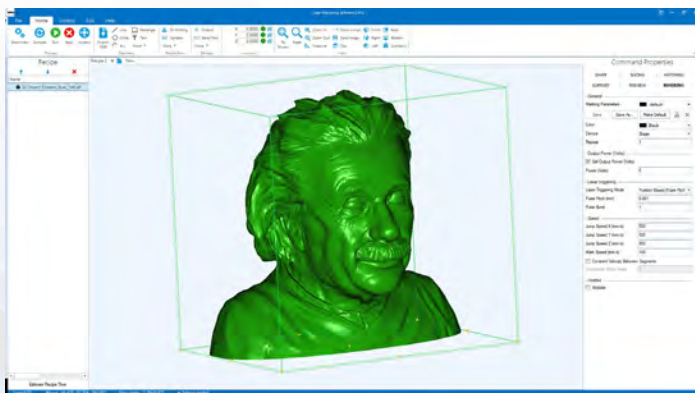

◀ Complete Hardware Integration Software for Laser Micromachining

- Complete Laser Process/Machine Control
- Converts DXF, DWG and STL files
- 3D Model View with run-time progress
- Build and run recipes on the fly
- Galvo/Stage synchronization for designs larger than Scan Field
- Powerful and intuitive software interface
- Customizable OEM interface

LMS Software is a comprehensive software package developed for single point control of laser materials process/machining workstations using either fixed beam or galvo scanners. The software takes and converts DXF/DWG/STL and other file formats and converts them to controller optimized trajectories with integrated fast laser control. With numerous features, including integrated support for vision systems, autofocus, and surface profilers, LMS provides advanced capability to any customer using Newport XPS controllers.

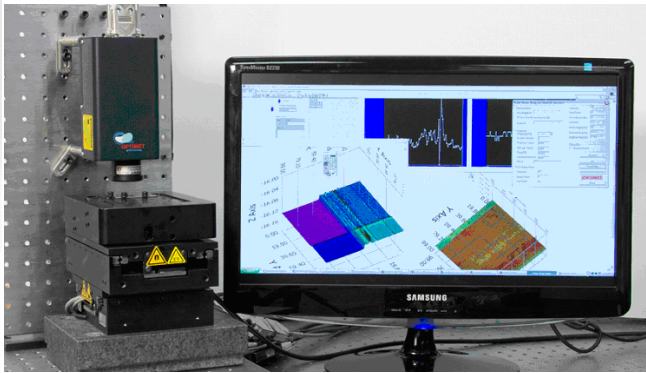

Optical Surface Metrology

High Performance Non-Contact Optical Surface Metrology System

Optimet sensors for distance & 3-D measurements with sub-micron accuracy

XM series ultra-high precision linear stages for exceptional flatness/straightness motion

XYZ integrated stage stack for multi-level scanning and easy adjustment

Integrated software driver libraries and communication protocols for robust, reliable control of motorized stages and Optimet sensor

A 3-D non-contact optical surface profiler system can be built using the NanoConoprobe and Newport motion products including XM series linear stages, VP-5ZA vertical stage and XPS-Q4 universal motion controller. This high-performance 3-D surface metrology system can be customized for a broad spectrum of fields from biomedical engineering to high precision manufacturing.

Micromachining

Laser μ FAB™ Microfabrication Workstation

Three-dimensional microfabrication by two-photon polymerization of photonics, microelectronics, and MEMS devices

Ablation of industrially relevant materials including metals, polymers, semiconductors, glasses, ceramics, and biological targets (laser milling, dicing, scribing and selective material removing)

Volume writing of waveguides and microfluidics in dielectrics

Nanosurgery for in vivo sub-cellular investigations in model organisms

Surface micro- and nano-structuring (sensors and bio-inspired materials)

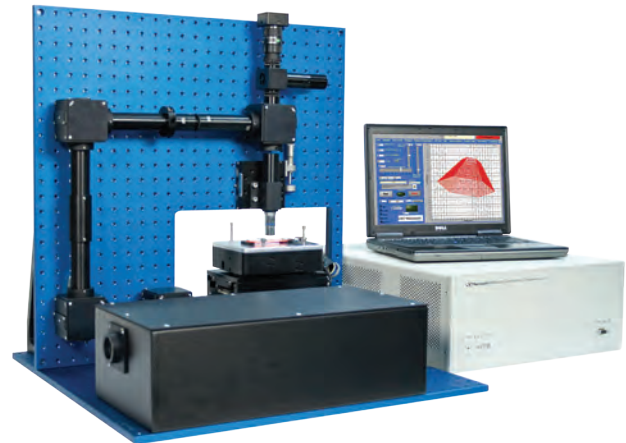

The Newport Laser μ FAB is a table-top easy to use micromachining tool for various applied materials research fields such as 3-D microfabrication by two-photon polymerization of photonics, microelectronics, and MEMS devices, laser ablation, volume writing of waveguides and nanosurgery. High end Newport stages are stacked in XYZ to move the sample around a fixed laser beam.

Manufacturing Workstation

Laser micromachining is a laser enabled process used to make micrometer scale features in materials. A pulsed laser deposits finite amounts of energy into a material for precise and reproducible material removal enabling the laser machining process to cut, scribe, drill, or ablate a material.

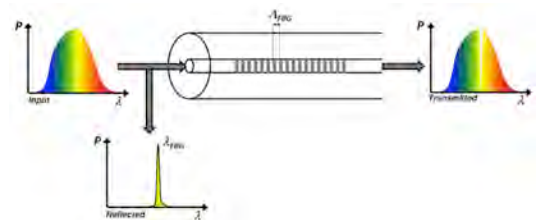
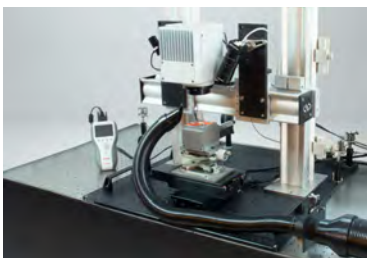

Branded Products

Agilis™ – Piezo Motor Driven Positioners

The new Agilis™ series of piezo motor driven miniature positioners takes a new approach to the adjustments needed for many optical setups. The Agilis series provides the ultra-high adjustment sensitivity and convenient remote operation of a motorized positioner at the price and size of a high quality manual component.



- Convenient, hands-off remote or computer automated adjustment of critical optical setups
- Impressive 50 nm (0.2 arcs) adjustment sensitivity
- Ultra-compact, ideal for space constrained setups and system integration
- Set and forget long term stability
- Comparably priced to a high quality manual component



Conex™ – Photonics Control Devices



The affordable Conex™ family of compact, photonics control instruments features devices that connect easily via USB plug-and-play technology and allow simple, but highly functional PC-computer control solutions. Multiple units can be connected to a single USB port and for CONEX-PSD9 and CONEX-IOD models, the USB port also powers the CONEX-CC modules, eliminating the need for additional power supplies and/or cables. The intuitive LabVIEW-based utility program software provides a graphical user interface (GUI) for each module. A comprehensive set of LabVIEW VIs (virtual instruments) is also available.



Picomotor™ – Piezo Motor Actuators

- <30 nm resolution in a compact design
- Set-and-forget long-term stability-
these actuators stay put
- Vacuum and ultra high vacuum
versions available



Picomotor™ actuators are ideal devices for motorizing fine-positioning stages and mounts in your optical or mechanical systems. Use them with our opto-mechanical translation stages or your own custom devices. They have better than 30 nm resolution with minimal backlash, and can exert a 22 N (5 lb) force. Moreover, they have exceptional long-term stability and the ability to hold their position with no power applied. These last two features make the Picomotor actuators unique among motion-control devices and ideal for typical set-and-hold applications.

NanoPositioning Stages



Piezoelectric-based, NanoPositioning products enable users to reliably manipulate samples and objects or adjust the beam focus in the nanometer realm. Applications include scanning, beam focusing, tool adjustment, sample manipulation, etc. Newport's piezo, NanoPositioning products include actuators, X, XY and XYZ stages, microscope focusing objectives, micrometer adjusters, ultra-fast steering mirrors and controllers. NanoPositioners feature high response and high speeds within their short travel range. Strain gage sensors enable higher repeatability and vacuum versions are also available as standard.

Vacuum Compatible Products

We use procedures to specifically prepare products for use in vacuum environments to ensure that our products will function as designed at pressure levels down to 10^{-6} hPa, and at the same time not release unacceptable quantities of contaminants into the vacuum environment. For proper preparation, more information in addition to operating pressure is needed. Acceptable levels of outgassing, mass loss, and volatile condensable materials can vary with the application, pumping capacity, temperature, etc.

Contact us for your ultra-high vacuum needs.



▲ URS Series
Rotation stage



▲ NSA Series
Motorized linear actuator



▲ LTA Series
Motorized actuator



▲ MTN Series
Mid-travel, steel linear stage



▲ HXP Series
6-Axis Hexapod



▲ Agilis™ – Compact piezo
driven optical mounts



▲ 8817-6-V
Motorized Stability™ mount

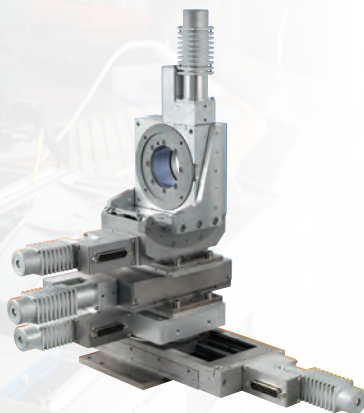

▲ Vacuum compatible standard
products assembly
UTS and URS V6 stages



▲ 8081-UHV
5-Axis Picomotor Kinematic Stage



▲ 8341-UHV
Picomotor Actuator

User Friendly ESP Technology



Exclusive to Newport, ESP is a proprietary, communication recognition channel system between stages and electronics. Minimizing system setup time and maximizing operational safety, this system brings you total peace of mind. Today, almost all of our stages and electronics are ESP compatible. It couldn't be simpler - during system boot, the motion controller retrieves all relevant information from a memory inside the stage and either self-configures to the connected hardware or checks for conformance to a stored configuration. ESP is the only system that provides true plug-and-play compatibility, avoiding accidental damage caused by the wrong configurations.

Furthermore, our motion electronics are equipped with the most advanced features and high-level commands to minimize the time for system optimization and application development. Examples of this technology in use include:

- Auto-scaling
- Auto-tuning
- Automatic jerk settings
- Auto-tracking
- Unidirectional motion mode avoiding the effects of backlash and hysteresis
- Programmable event triggers
- Motion done trigger signal taking into account system settling times.

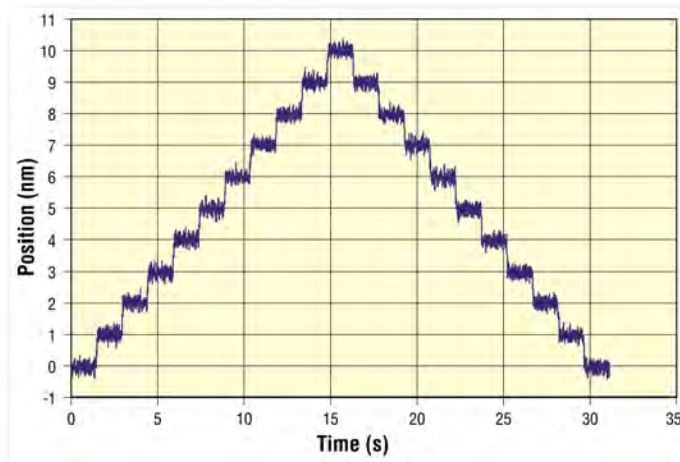

◀ 1 nm MIM with the XM series linear motor stages. Nanometer MIM with long travel.

Last but not least, all of our stages and electronics have standard mechanical and electrical interfaces for maximum compatibility and interchangeability. We do not only talk about ease of use, we apply it.



Engineered Systems

In addition to an extensive offering of standard motion products and OEM work, we provide custom motion systems tailored to unique application needs. Our systems engineering team is focused on developing high precision custom systems solutions for research and industrial end users. Whether you require an adaptation of a standard product, a simple sub-assembly or a complex multi-axis system, Newport motion is your right partner. We shall assist you with the feasibility study of your application, recommend the solution that best meets your needs, and provide support throughout the lifetime of the motion system. In addition and up to final acceptance, our systems engineering department provides project management that ensures timely delivery of a motion system that meets or exceeds the expected system performance. The latter is guaranteed by extensive testing and metrology during the manufacturing process as well as on site.

Four levels of custom motion systems are typically provided:

1. Adaptations of Standard Products

Whether the change involves a cable, mechanical adapters, metrology, or an environmental preparation of a motion component, the systems engineering team handles your special adaptation requirements with highest efficiency.

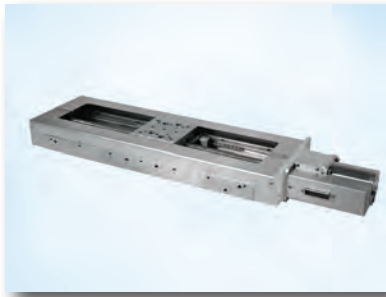

◀ *Vacuum compatible MTN-PPV6 stage:
Most of Newport's positioners can be prepared
for vacuum environments up to 10^{-6} hPa, in
some cases up to 10^{-9} hPa*



*Example of an X-Y-theta assembly
entirely built by standard products:
Newport provides orthogonality and
sphere of confusion alignments including
metrology reports upon request.* ▶



◀ *Newport offers custom length or
environmentally prepared cables that
ensure the integrity of your application.*

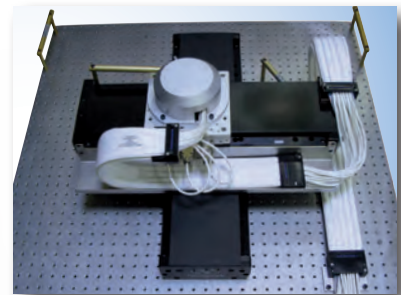

*Newport provides clean standard
solutions for cable routing including
supplementary cables and vacuum tubes
per individual requirement.* ▶

2. Special Motion Devices

For years, our systems engineering team has been designing and manufacturing special motion devices for niche applications such as high energy laser fusion systems and synchrotrons. Examples include high class clean room compatible, high-load motorized actuators, binary inserter devices, motorized mirror mounts, very long travel linear stages, and large scale rotation stages.



▲ **Actuator:**
High resolution and high load capacity actuator for high power laser facility mirror mount. High level of cleanliness.

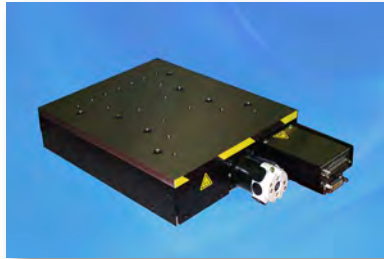

▲ **High Resolution Z-Stage:**
Vertical linear stage with 10 nm sensitivity, 20 kg load capacity using backlash-free ballscrew and steel construction.

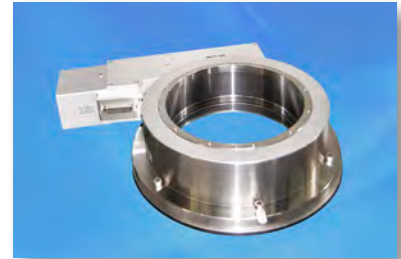

▲ **RVU240:**
High sensitivity, high torque, high angular stiffness rotation stages providing 5 μ rad sensitivity and 0.1 Nm/ μ rad angular stiffness.

3. Sub-Assemblies

These are economical solutions made exclusively from our standard catalog components. We add value by optimizing the performance level of these components to your requirements and commit ourselves to the global specifications of the system by performing metrology before delivery.



◀ **Sensor calibration bench for car-safety systems in automotive industry.**
11 catalogue stages in 3 stacks with custom brackets and interface plates.

Azimuth/elevation gimbal with 350 mm diameter for LIDAR analysis, target tracking or optical sensor testing. ▶

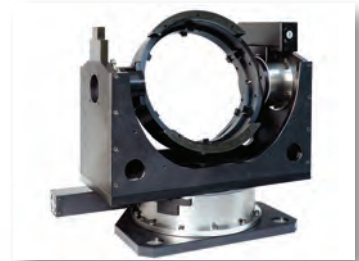

◀ **24 axis system for alignment of a variety of telcom devices, built from standard stages. The system includes pick and place capability of optical components.**

High speed 2-axis motion simulator using RGV series for continuous 360° rotation, speeds up to 720 °/s, high acceleration, 0.001° MIM for MEMS-based inertial sensors testing. ▶



◀ **Ceramic guide along with the redesigned XY carriage are made from a new SiC ceramic material that is 1.5 times stiffer and 5 times more stable.**

Please contact us for your gantry needs.

4. Advanced Customized Systems

These tailor-made pieces of technology represent the pinnacle of our system design capabilities. In addition to the traditional electro-optical components, these multi-faceted systems typically include application specific sensors or devices, application software and system-level safety features. System level safety features are not limited to safety interlocks, but can include collision and simulation algorithms. Metrology and testing are two of the most intensive phases of the development of these systems that clearly distinguish their superb performance on site. Examples are: X-ray diffractometers, metrology systems, and various sample positioners.



◀ We design and manufacture motorized mirror mounts for high power laser facilities. These mounts accommodate a variety of large optics for laser beam up to 600-mm diameter in very demanding environmental conditions (cleanliness, vacuum).

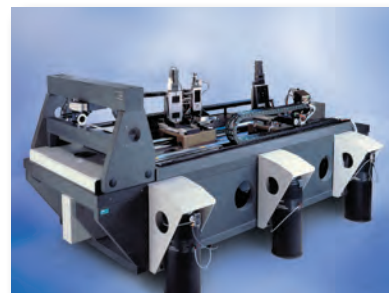

Air-bearing system:
This system was designed for large-scale assembly and testing of optics. The multi-axis system features a very rigid silicon carbide and granite structure for superior stability and flatness, 19 motorized axes for alignment and positioning and 2 long travel air-bearing stages driven by linear motors. ▶



◀ *Vibrometer test bench:*
3-axis system used at the LCPC (Roads and Bridges laboratory) to measure the density of large concrete blocks. A shock is created in one point with an explosion, the resulting vibrations are measured in another point for analysis of the concrete density.

OEM – Developing for the Future

«Our reputation as the leading motion supplier to OEM's is hard-earned.

*Product performance, cost, delivery, and quality directly impacts
your competitiveness – and that is why we get it right the first time!»*

Our dedicated OEM group focuses solely on the unique requirements of OEM customers. This experienced, professional department was developed as a small worldwide group within a large company – hence, you get the best of both worlds. Draw upon the resources that a large company offers and get the individualized service and rapid response of a small company.



Your Project Matters

Our OEM strategy is to offer our customers a competitive advantage in their marketplace by providing direct access to our expert resources – engineering, manufacturing, logistics, and service organizations. We thoroughly evaluate a product, sub-assembly or sub-system from every angle to perform a rapid and in-depth feasibility review. During this initial assessment process, we determine the value we add based on our core technologies and competencies.



Working as Part of Your Business

We are with you every step of the way, with a team consisting of engineering, manufacturing, logistics, marketing and customer service for maximum support. We view this team as an integral part of your organization that reports directly to your project team.

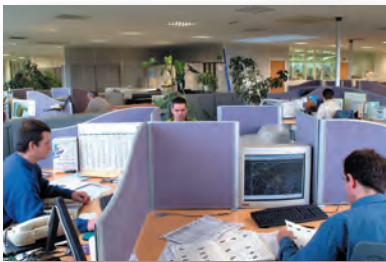

Discretion at All Times

Your program's confidentiality is imperative and we make special provisions to ensure that the highest levels of confidentiality are maintained. Non-disclosure agreements are signed up-front before we begin technical discussions and design ownership issues are firmly established. Upon request, we will dedicate work cells for your application to ensure total confidentiality within our company for your own peace of mind.

Full Design and Manufacturing Control

Our OEM project leaders use a controlled procedure to manage your project. Complete BOMs are developed and controlled through our formalized ECO process with all assembly and test procedures fully and formally documented.

The Optimum in Quality Control



Our Newport brand operates under the ISO 9001 registered quality system. As a result, our exemplary quality system is audited by a third party. As a further measure of our commitment to quality, we perform internal audits routinely to ensure we are compliant with our procedures. We ensure that quality is built into the process and monitor quality through closed-loop performance metrics.

We Make It Right

Should things not go according to plan, we have put in place closed-loop corrective action systems. Complaints are entered into our customer management database and made directly accessible to our executive staff. This information is then reviewed for immediate corrective action. Once the root cause and course of corrective action has been determined, this information is provided to you in writing.

Examples of OEM Products

The Newport brand is at the cutting edge of OEM technology and design, delivering standard and bespoke value for money solutions in materials, manufacturing, assembly and motion control. Our solutions serve a broad variety of applications from lithography and photovoltaics to industry, research and defense.



◀ Laser Radar Atmospheric Observation

High-speed, low profile rotation stage developed for a LIDAR remote atmospheric observation system. The stage is based on the URS100 rotation stage and features a precision belt drive to achieve a scanning speed of 720 °/s. The wobble error is maintained within 50 μ rad.

Automotive Sensor Testing ▶ Standard BGS80PP Goniometric cradle with custom stepper motor used for quality control of adaptive cruise control sensors for the automotive industry. Another application for the same stage is for calibrating laser targeting systems. These goniometric cradles rotate on a transverse axis above the platform and offer maximum free access to the rotating part. This simplifies system layout compared to the use of 360° rotation stages.



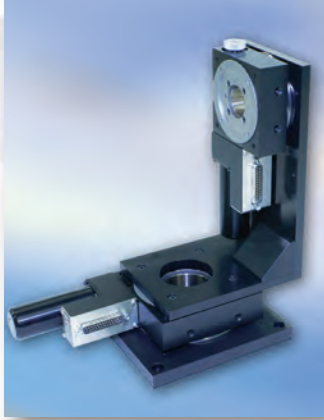

◀ Aviation Simulation

Azimuth/elevation system used for image alignment within a professional aircraft simulator. The system is made of standard rotation stages with custom brackets and metrology.

3D Micro-Fabrication ▶

X-ThetaZ-Y-ThetaZ motion system for high accuracy 3D micro-fabrication of ceramic components by micro-deposition (ink-jet technology). Newport developed and delivers the complete motion platform including granite structure, cable management and control electronics. The application requires a dynamic accuracy of $\pm 3 \mu\text{m}$ accuracy over $300 \times 300 \text{ mm}$ while the stage is moving at 500 mm/s speed. Other demanding requirements are less than 300 ms settling time and 20 nm incremental motion on the lower Y-axis.

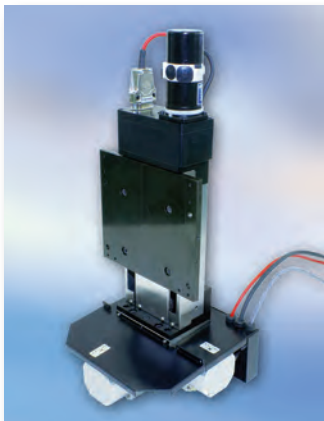
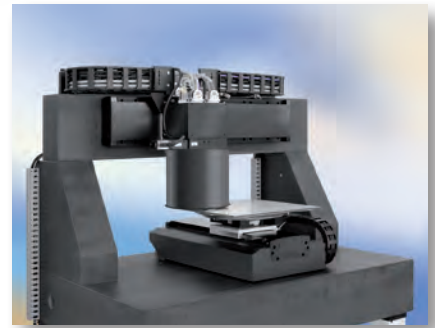

◀ Electrical Discharge Machining

XYZ linear stage assembly for electrical discharge machining. The application requires high repeatability in XY and very high stiffness and straightness in vertical direction. More than one hundred of these machines are installed worldwide and have continued to work successfully many years, 24 hours per day.

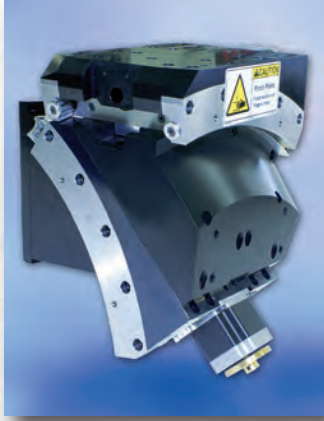

◀ Optical Surface Profiling

This custom cradle assembly is used for motorized tip and tilt motion in an optical surface metrology system. The assembly allows large angle tilts without lateral motion of the field of view. As the system rotates the entire microscope scan head, a high load capacity and position stability is required.

Tactile Metrology for Optic and Automotive Industry ▶

3-axis part handling system for automated surface form and finish measurement of multi-featured parts. Newport supplies allow fully automated measurement routines to reduce operating errors and to free up operators time. The high stability and repeatability of the motion stack allows highly repeatable measurements, crucial especially when analyzing features such as small angles and radii.

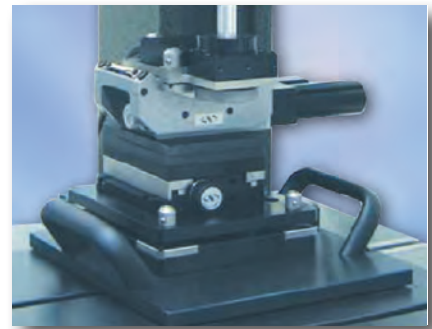

◀ Film Thickness Measurements

Non-contact film thickness and refractive index measurement tool for the semiconductor and solar industry. This tool is mainly determined for R&D and off-line production quality control. The use of standard motion components allows a flexible adaptation to specific customer needs.

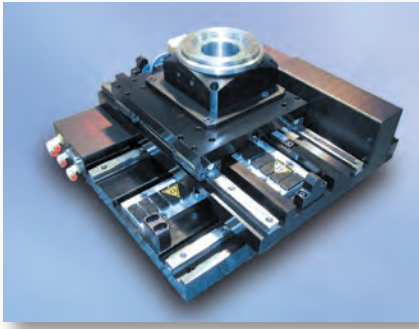

◀ Semiconductor Wafer Metrology

This XY-ThetaZ motion system allows in-situ inspection of 300 mm wafers on a minimum footprint of 450 x 450 mm. Throughput, low-cost, accuracy, and cleanliness were major design criteria in the development of this sub-system, which can yield speeds up to 300 mm/s and 720 °/s and accuracies down to 10 μm over the surface area of the wafer.

Flat Panel and PCB Inspection ▶

This system is used for large area 3D critical dimension metrology of flat panels and PCB's. The split gantry system allows inspection of large panel sizes up to 600 x 600 mm on a minimum footprint. Newport delivers the complete motion sub-system including granite, vibration isolation and control electronics.



◀ Maskless Lithography and Micro-Manufacturing

This special version of our LTA actuators provides 120 N axial load capacity, a non-rotating tip and spherical joints on both sides. It is perfectly suited for building custom multi-axis motion devices. Typical applications are custom Z-tip-tilt platforms for micro-manufacturing, maskless lithography of PCB's, and flat panel processing/inspection.

Laser Scribing of Thin-Film PV Cells ▶

IMS-LM linear motor stages provide fast and accurate scribing of PV substrates yielding the smallest possible dead zones.

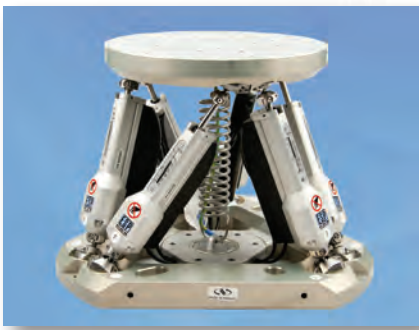
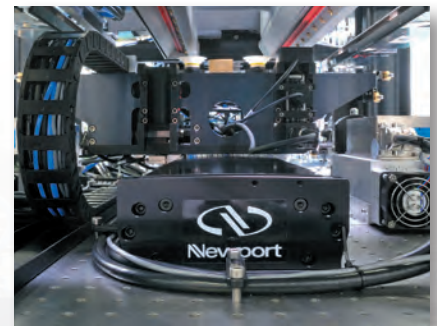

◀ Quality Control

Hexapods offer motion in all 6 degrees of freedom (XYZ, tip, tilt, and rotation) in a very compact envelope and with maximum access to the moving platform. They are ideally suited for complex quality control, simulation or calibration systems that need to control several degrees of motion.

Precision Actuation in Engineered OEM Sub-Systems



▲ Integration of precision actuators into custom-designed beam-alignment systems.

- Picomotor™ OEM actuators with <math><30\text{ nm}</math> precision
- OEM high-speed actuation platform
- Engineered sub-systems
- Sophisticated control electronics

Our New Focus™ precision Picomotor™ actuators are widely used in OEM applications including semiconductor lithography, industrial manufacturing, metrology and test applications. Picomotor actuators deliver 30 nm set-and-forget precision motion control and are customized for UV, vacuum, high-radiation, e-beam and other OEM environmental conditions. For instance, our Ultrahigh-Vacuum (UHV) Picomotor actuators and Picomotor Actuator Ultra are very low-outgassing actuators proven in demanding OEM applications. For closed-loop performance, these actuators can incorporate encoders.

Additionally, we provide engineered OEM sub-systems incorporating our Picomotor actuators and customized OEM opto-mechanical components and assemblies. These OEM precision motion control solutions are engineered for OEM-specific requirements and are customizable for OEM environmental conditions.

To complete the solution, we also deliver sophisticated control electronics to drive the actuators using feedback devices. Beyond our standard drivers and controls, we engineer custom control electronics for OEM applications.

Partnering for Success – Newport’s OEM Technology Platforms

We have built upon decades of experience in motion solutions to partner with customers in creating customized OEM technology platforms that cater to application-specific needs. These platforms have been successfully implemented in partnership with OEM’s in the semiconductor industry in wafer inspection and lithography applications, for example. Other applications include flat panel display (FPD) inspection and processing and laser scribing of thin-film photovoltaic panels.

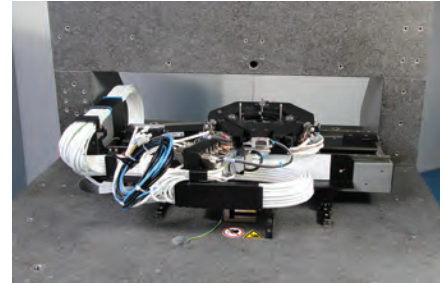

These customized technology platforms are designed from leading technologies and combine our collective knowledge in materials, manufacturing, assembly and motion control. Technologies such as air bearings, linear and rotary ball bearings, high resolution direct encoders, linear motors, piezos, flexures, ceramic materials and vibration isolation are optimally integrated into these platforms to address the customer’s specific requirements.

A major part of this technology knowledge comes from supplying numerous and proven standard motion products over the years to industry, research and defense.

We support the customer’s product development process by engaging early on with collaborative discussions on the requirements and solutions until the optimum platform that meet those requirements is agreed upon. Collaboration continues past stages of development into the actual implementation of the platform into the customer’s final product.

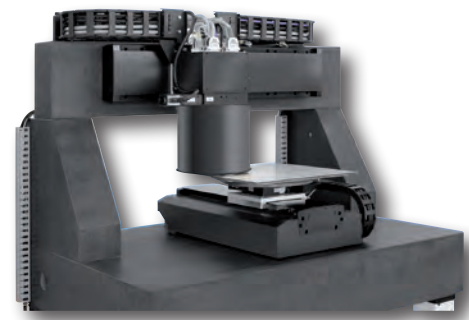

OEM Project Leaders

We are with you every step of the way, with a team consisting of engineering, manufacturing, logistics, marketing and customer service for maximum support. We view this team as an integral part of your organization that reports directly to your project team.

Your Foundation of Support

Behind our OEM group are highly skilled teams of engineers and scientists who help you configure a solution to your specific application. Working together in an open, collaborative basis to solve problems has proven to be the fastest, most efficient method to deliver results.

Service and Support

We have a global infrastructure to ensure that after sales service and support extends on-site, at your facility or your customers facility. Our ability to solve your problems has no borders or time restrictions. Cooperative service agreements and extended warranties for specific support levels are available. Our factory-trained technicians bring test equipment and spare parts on-site to service our systems. Metrics can be established to track your product’s service history.

Air Bearing Stage Capabilities & Solutions

Our reputation for being the premier supplier of high-precision motorized stages is exemplified by our full line of Air Bearing Positioning Systems. From the all-new DynamYX® Datum® capable of 5 G acceleration and nanometer accuracy to the evolutionary HybrYX™ air and mechanical bearing “hybrid” stage, we have the knowledge and expertise needed to address the most complex and demanding motion control applications.

The Newport brand currently offers air bearing solutions from three families of products. For the highest levels of positioning performance in all categories DynamYX offers single-plane air bearing designs for both wafer and reticle applications. The HybrYX™ family blends mechanical bearings with air bearings in a single-plane architecture to provide a cost-effective solution for applications where performance is only needed in a few key areas. For single axis, split XY, and gantry applications the SinguLYS™ line of stage and self-supporting bridge configurations combine high performance with modularity ideal for a wide range of markets. Within each of these three families are a variety of features and options intended to suit the specific needs of your application.

▼ DynamYX® Technology



- Single plane XY air bearing
 - Granite base
 - Ceramic moving elements
 - Integrated pressure vacuum air bearing elements
- Ultra-low profile architecture

DynamYX air bearing stages are focused on applications requiring the highest levels of accuracy, repeatability, and overall system throughput.

▼ HybrYX™ Technology



- Single plane XY air bearing hybrid
 - Granite base
 - Ceramic Y-axis carriage
 - Integrated pressure vacuum air bearing elements
- Truck-and-rail mechanical bearings

HybrYX stages are engineered to provide exceptional velocity regulation, straightness, flatness, and MTBF.

▼ SinguLYS™ Technology



- Single-axis air bearing
 - All-ceramic construction
 - Integrated pressure vacuum air bearing elements
- Stage and bridge configurations

SinguLYS family provides a modular approach for single-axis, split-XY, and long-travel Gantry Applications.

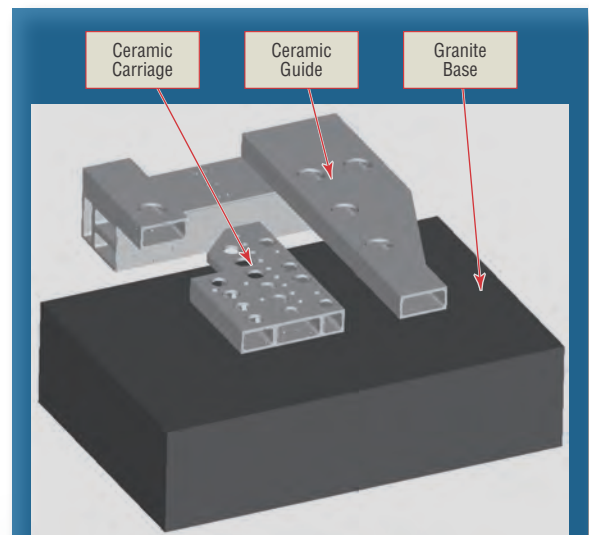

Clean and Simple Architecture of DynamYX includes Three Monolithic Elements

Our philosophy of “designed-in” precision is a shared feature of all Newport air bearing stages. Our designs minimize the number of stage elements (bases, carriages, reference surfaces) and incorporate critical alignment (reference) features as to greatly reduce and/or eliminate the need for complex (and costly) assembly, alignment, and testing procedures. This design philosophy is achieved by creating monolithic structures with tolerances integral to the manufacturing process of each component.

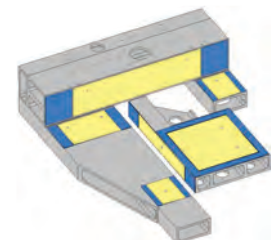
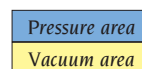

Newport stages feature pressure-vacuum air bearings that are directly machined into the ceramic elements. ▶

DynamYX[®] Family of Stages for Semiconductor Wafer Processing and Inspection

We are heavily involved in wafer processing and inspection, supplying the DynamYX[®] to the industry. DynamYX was designed to provide equipment manufacturers in the semiconductor industry with a tool capable of achieving the highest levels of precision and throughput. DynamYX provides high resolution dynamic positioning of a wafer chuck or other similar substrate in two orthogonal translation axes from a single-plane carriage. A vertical (Z) axis with tip-tilt function and a rotary axis for wafer offset correction may be added on the carriage beneath the wafer chuck. Over the years, the form and function of DynamYX has evolved to keep pace with customer requirements. Today the DynamYX family consists of four specific designs each with their own specific features and benefits:

▼ DynamYX[®] Datum[®] 300 and 380GT



Key Performance Values

- Designed for 300 mm wafer test, measurement & processing applications
- Extremely rigid structure and high load capacity air bearings
- Acceleration: up to 2g
- Velocity: 400mm/sec
- Repeatability: $\pm 50\text{nm}$ (long term)
- Accuracy: $0.4\mu\text{m}$
- Available with patented ZT3, Z-Tip-Tilt-Theta stage

Designed for 300mm wafer test, measurement, and processing applications, the DynamYX[®] 300 Wafer Positioning Stage features a simple three-piece architecture in a two motor design that provides a cost effective solution for high accuracy and dynamic performance for step-and-settle and/or scanning applications. On the other hand, the DynamYX[®] GT stage is intended for high-throughput applications with aggressive duty-cycles. Featuring an extremely rigid structure and high load capacity air bearings, it provides up to 2G acceleration. The DynamYX GT also has high-efficiency X and Y linear motors with integrated cooling, while driving moving masses through their respective center of gravity.

▼ **DynamYX® 300**



Key Performance Values

- Acceleration: 0.75 G X-Axis, 1.5 G Y-Axis
- Velocity: 400 mm/s
- Repeatability: ± 50 nm (long term)
- Accuracy: 0.4 μ m
- Travel range: 520 x 340 mm

The DynamYX 300 was introduced more than 10 years ago as the first single-plane dual-axis Air Bearing system for 300 mm wafer inspection applications. Today, it is still a very capable solution for demanding applications such as wafer bump inspection, nano imprint lithography, laser direct writing, or optical calibration, and provides the smallest footprint of all DynamYX stages.

Key Performance Values

- Acceleration: 1.2 G X-Axis, 2 G Y-Axis
- Velocity: 800 mm/s
- Repeatability: ± 50 nm (long term)
- Accuracy: 0.3 μ m
- Travel range: 520 x 340 mm

Similar in design to the DynamYX 300, the DynamYX GT is intended for higher throughput applications with aggressive duty-cycles such as optical lithography or memory repair. Compared to the DynamYX 300 stage, the GT version has larger linear motors with integrated cooling in X & Y, a second (X2) linear motor, and more rigid structure with larger air bearings for increased load capacity.

▼ **DynamYX® GT**

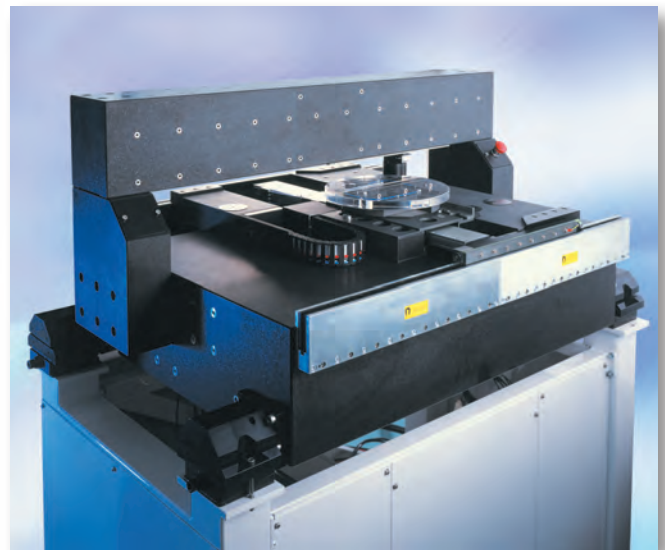

▼ DynamYX® Datum®



Key Performance Values

- Acceleration: 3 G X-Axis, 5 G Y-Axis
- Velocity: 1000 mm/s
- Repeatability: ± 25 nm (long term)
- Accuracy: $0.2 \mu\text{m}$ (linear encoders)
- Natural frequency: 300 Hz

The all-new DynamYX® Datum® achieves performance never before possible in a commercially available air bearing stage. Datum is the bi-product of our continuous investment in advanced materials, proprietary fabrication techniques, and meticulous structural analysis and design. Our goal in creating Datum was to provide our customers with accuracy and throughput needed for today's most demanding semiconductor applications as well as the ability to stay-ahead of tomorrow's challenges. The DynamYX Datum stage meets the most challenging requirements for high aspect ratio wafer inspection, and optical or nano imprint lithography.

Key Performance Values

- Travel range: 290 x 155 mm
- XYZ position stability
 - On-air: ± 10 nm
 - Clamped: ± 1 nm
- XY repeatability ⁽¹⁾: ± 50 nm
- XY accuracy ⁽¹⁾: $1 \mu\text{m}$
- Natural frequency (reticle holder): 400 Hz

¹⁾ After clamping.

The DynamYX® RS is dedicated to reticle inspection and repair applications. It is based on the same single plane architecture found in the DynamYX 300 & GT stages with a cantilevered substrate holder located away from all moving elements of the stage providing the cleanest possible environment. The full-open-aperture accommodates flexible optical component integration as well as ease of service access. The footprint of this architecture is much smaller than traditional open-frame solutions.

▼ DynamYX® RS Reticle Stage

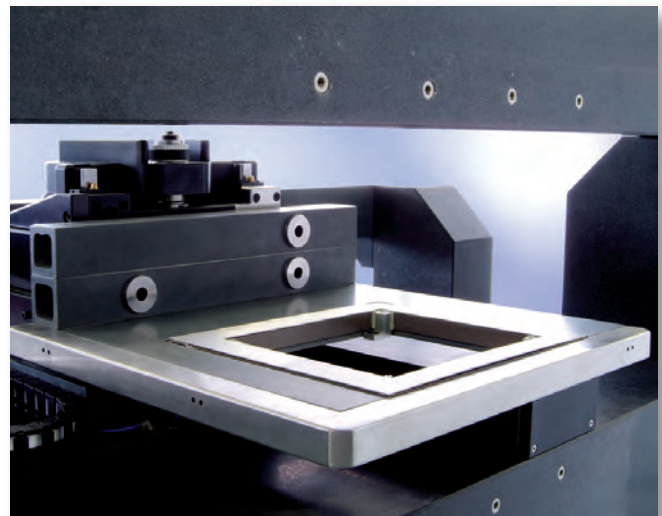

HybrYX™ – High-Performance Solutions for Semiconductor Wafer Inspection, Flat Panel, PCB and Photovoltaic Applications

The HybrYX™ single plane XY hybrid stages provide the advantages of a single plane air bearing stage at a much lower cost than previously possible. HybrYX is well suited for semiconductor wafer inspection systems as well as being an excellent choice for use in large substrate (flat panel display and photovoltaic panel) inspection and processing tools.

▼ HybrYX™ XY Hybrid Air Bearing Stage



HybrYX™ stages blend the cost-effectiveness of mechanical bearings with the precision of a single plane air bearing carriage to deliver a powerful combination of throughput, precision and value for demanding scanning applications.

Key Performance Values

- Travel range: 350 mm (step) x 650 mm (scan)
- Acceleration: 0.3 G (step)-Axis; 0.6 G (scan)-Axis
- Scanning velocity: 600 mm/s
- Better than 0.1% velocity ripple
- Step-and-settle time (25 mm, ±40 nm): <350 ms
- Accuracy: ±1 μm (over 300 x 600 mm)

▼ HybrYX™ G5 Large Substrate Positioning Stage

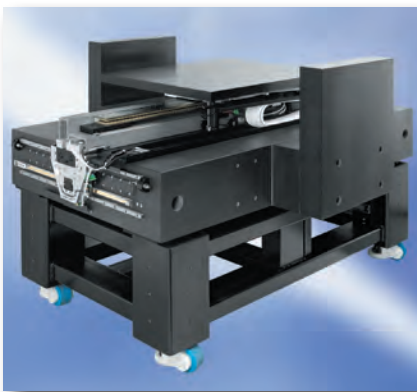

The HybrYX™ G5 is closely based on the smaller HybrYX stage, but with larger ceramic carriage and Y-axis beam. It is well suited for up-to Generation 5 flat panel display substrates or photovoltaic panels.

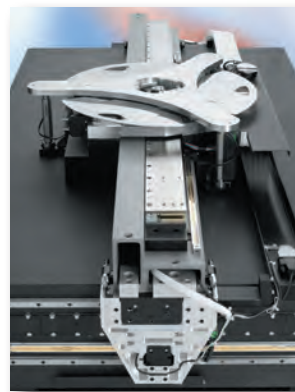

Key Performance Values

- Travel range: 450 mm (step) x 1400 mm (scan)
- Acceleration: 0.15 G (step)-Axis; 0.25 G (scan)-Axis
- Scanning velocity: 1200 mm/s
- Better than 0.1% velocity ripple
- Step-and-settle time (25 mm, ±40 nm): <350 ms
- Accuracy: ±3 μm (over 400 x 1200 mm)

◀ The G5 stage is available with an optional Z-Tip-Tilt-Theta stage which incorporates our patented flexure guide found in the DynamYX GT stage. Like the DynamYX version, Active Plane™ drive technology provides fast, repeatable, and stable positioning for active surface tracking applications.

SinguLYS™ – Single Axis Air Bearing Stage and Bridge

SinguLYS™ S-370 Air Bearing Stage ▶

The Newport SinguLYS™ S-Series stage features ceramic components similar to those found in the DynamYX and HybrYX families. The light-weight carriage with integrated pressure-vacuum elements is guided by a precisely lapped ceramic (L-shape) body. The rigidity and compact footprint of the SiC body allows this high-precision stage to be used in tight spaces typically reserved for mechanical bearing designs. The S-370 is perfect for applications with very high duty-cycles and require low pitch/yaw, tight velocity regulation, and high cleanliness.

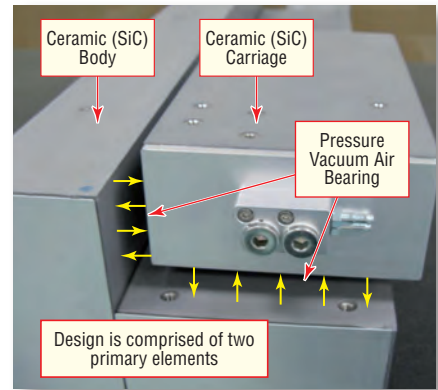

- Ceramic body provides extremely straight and flat reference surface over full travel of stage
- Ceramic carriage provides thermally stable reference and low moving mass

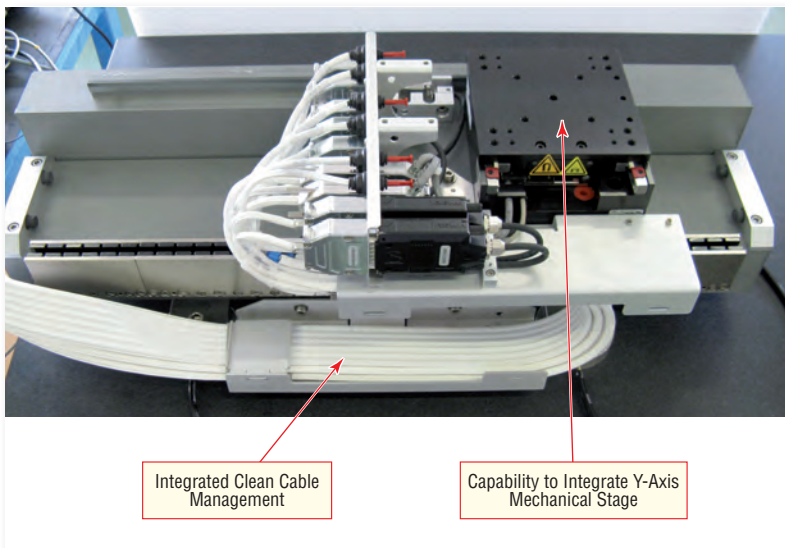

Key Performance Values	
●	Travel range: 370 mm
●	Incremental motion: 10 nm
●	Max. speed: 500 mm/s
●	Max. acceleration: 0.5 G
●	Payload: 5 kg
●	Controller: XPS / DRV02
●	Dimensions (mm): 640 (L) x 300 (W) x 150 (H)

SinguLYS™ B-1200 Air Bearing Bridge ▶

The Proprietary SiC ceramic beam used in the SinguLYS B-Series Bridge is 3 times lighter than steel and offers triple the stiffness of granite. These properties have allowed our customers to increase throughput in current and next-generation Flat Panel Display Inspection tools. The light and rigid pressure-vacuum air bearing carriage accommodates high (10 kg) cantilevered payloads and significantly reduces contamination to the payload below. Besides cleanliness, the frictionless design eliminates the need for mechanical bearing maintenance/lubrication.



Well suited applications include:

- Gen 8-11 flat panel display processing
- Thin film photovoltaic scribing
- Precision pick & place assembly
- Laser micromachining
- Split XY wafer processing

Key Performance Values	
●	Travel range: 1200 mm
●	Rated payload: 10 kg
●	Max. speed: 2.5 m/s
●	Max. acceleration: 2 G
●	Efficient iron-core linear motor
●	Natural frequency: >100 Hz

ZT3 Z-Tip-Tilt-Theta with Active Plane™ Technology

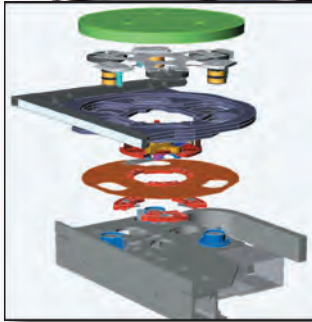
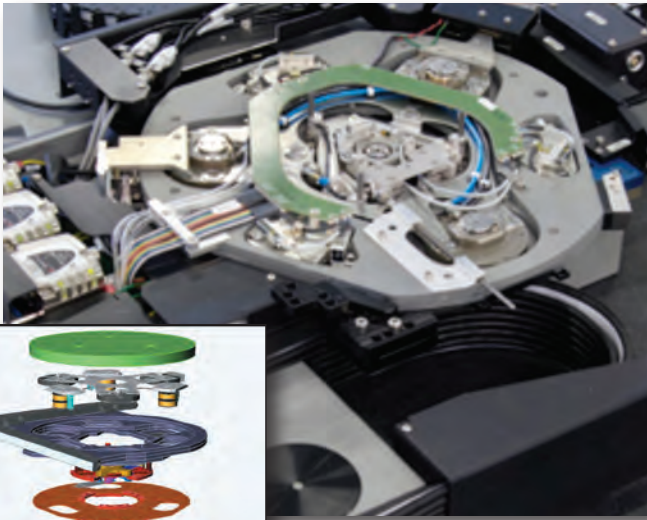

▲ ZT3 shown as integrated assembly with DynamYX GT air bearing stage.

The patented ZT3 (Z-Tip-Tilt-Theta) is designed for applications such as optical lithography or wafer inspection that require active alignments of a wafer/chuck in vertical, tip, tilt, and theta. The Active Plane™ drive technology provides high-bandwidth repeatable and stable positioning without compromising the dynamic performance of the XY stage. The ZT3 integrates cleanly within the SiC carriage of DynamYX® GT and DynamYX® Datum® stages and is also available as a standalone version for use with other high performance XY stages. The compact design includes an air bearing theta off-set stage which clamps for ultimate stability and a lift-pin mechanism for simplified wafer loading and unloading. An optional piezo driven fine-theta axis with 0.1 μ rad sensitivity may be added to allow for active yaw control/compensation.

Key Performance Values	
● Travel Range:	5 mm Z; ± 2 mrad (tip/tilt); $\pm 3^\circ$ (Θ_z)
● High resolution linear encoders	directly measure movement of all voice coil driven axes
● Minimum incremental motion:	5 nm
● XY Stiffness:	>200 Hz
● Step & Settle:	5 μ m displacement in 40 ms settled to ± 20 nm



The ZT3 concept is homogenous with the DynamYX GT/Datum concept in that both are low mass, low profile, high stiffness, and non-contact design philosophies. With a chuck surface height of 113 mm above the top surface of the reference granite, a DynamYX GT with integrated ZT3 is the industry's lowest profile 6-axis air bearing positioning system.

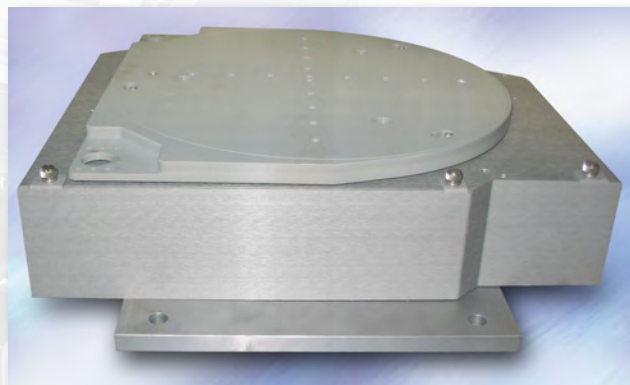

◀ Metal enclosure of standalone ZT3 shield internal components from surrounding environment

Other compensation or correction tools are available, for example, yaw or straightness correction, and flatness correction

Capabilities in Advanced Ceramic Materials

Our expertise in ceramic materials is “home-grown” with a team of engineers specialized in material science and a fully equipped in-house machining center. These R&D and manufacturing resources allow us to quickly react to challenging customer requirements as well as maintain a constant effort in product advancements needed to keep pace with industry road maps.

The basic properties of these core (ceramic) components used in the construction of our products are low mass (density is similar to aluminum) and high strength or stiffness (Young’s modulus similar to steel). In addition to stages which have very high accuracy and throughput capabilities, our systems are thermally stable with clean and repeatable transfer functions capable of being tuned with ease in applications requiring high servo bandwidth.

Beyond positioning in the XY plane, we offer several options for precise control in Z, Tip, Tilt, and Theta, and can provide integrated solutions which include ceramic wafer chucks, lift pin mechanisms, and precision SiC interferometer mirrors with cost-effective replicated optical surfaces. Requirements for integrated optical bridge structures are often met using our expertise in granite and/or ceramics. When used with our XPS and SPS motion controllers our Newport air bearing stages achieve the highest level of positioning performance by virtue of sophisticated control algorithms, multi-dimensional error mapping, proprietary low-noise encoder interpolators, and integrated interferometer control boards.

▼ Ceramic Wafer Chuck

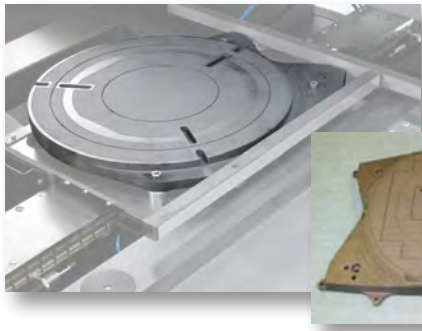

◀ SiC wafer chuck on DynamYX® Datum®.



◀ Support for 200 & 300 mm wafers, <2% backside contact, 100 nm flatness per 50 mm² area.

Key Performance Values

- Provides lower mass and greater flatness
- Thermal coefficient of expansion values of stage and chuck are matched
 - Allows for direct mounting of chuck to carriage
 - Best possible wafer surface flatness and stability
- Minimal contact design for exceptional backside cleanliness

Key Performance Values

- Two or three axis measurement at plane of wafer
- Ceramic (SiC) mirrors with master replicated surfaces
 - Allows for direct mounting of mirrors to chuck
 - Replica process yields exceptional mirror quality and is more cost-effective than lapping
- High thermal conductivity (> zerodur) minimizes thermal surface distortion
- Rigid material with very high (~900 Hz) natural frequency

▼ Interferometer Feedback and SiC Mirrors

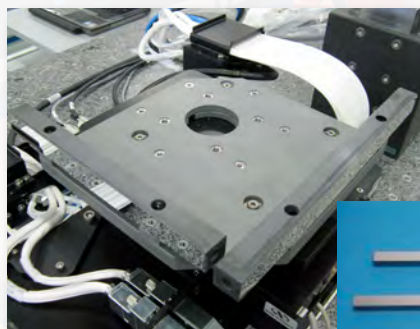

◀ Ceramic plate with integrated (replica) interferometer mirrors on Newport XML crossed roller bearing stages can provide 50 nm XY bidirectional repeatability (when used with XPS controller and Renishaw interferometer).



◀ Thermally matched mirrors are directly affixed to ceramic wafer chuck.

▼ Very Large and Rigid Ceramic Bridge Structures

Most of our systems are delivered with an overhead bridge structure that allows direct integration of the optical system. The bridge structure is an important piece to meet the overall system performance as precision and position stability are typically defined between the wafer and a reference point on the bridge. We have tremendous experience in materials and structural analysis and provides the optimum design solution for each application.

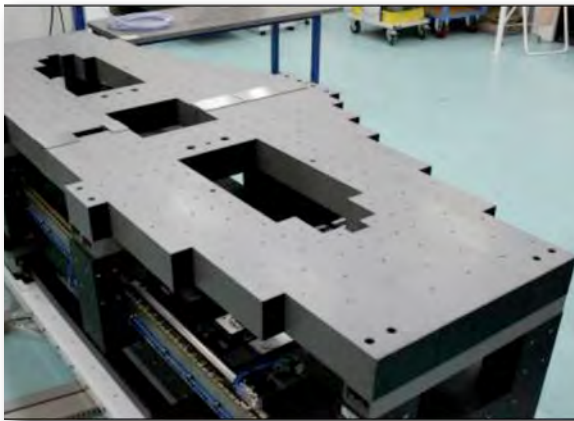
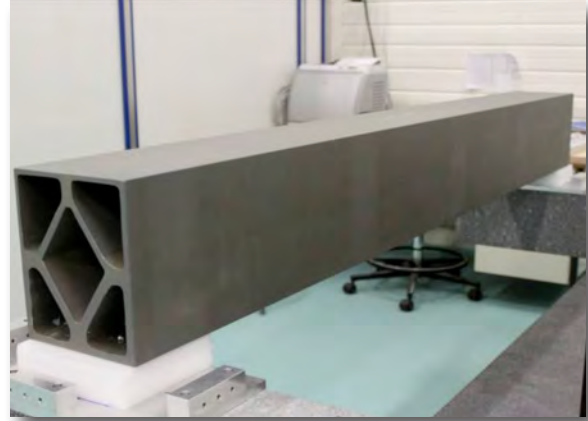

Material Properties of SiC, Granite and Other “Traditional” Air Bearing Stage Material

	Granite	Steel	Aluminum	SiC
Density: d	3	7.8	2.7	2.7–3.0
Young's Modulus: E , (GPa)	70	210	70	210–350
Stiffness (E/d)	23	27	26	78–115
Thermal Conductivity: TC (W/m*K)	2	50	150	30–140
Thermal Expansion: TE ($10^{-6}/K$)	5	11	22	4.0–4.8

▲ This material properties table above illustrates the advantages of Silicon Carbide (SiC) ceramic over other materials commonly found in stage and bridge designs. Newport has developed capabilities around several forms of SiC material and applies the technology according to the requirements of the given product or application.

Newport.com

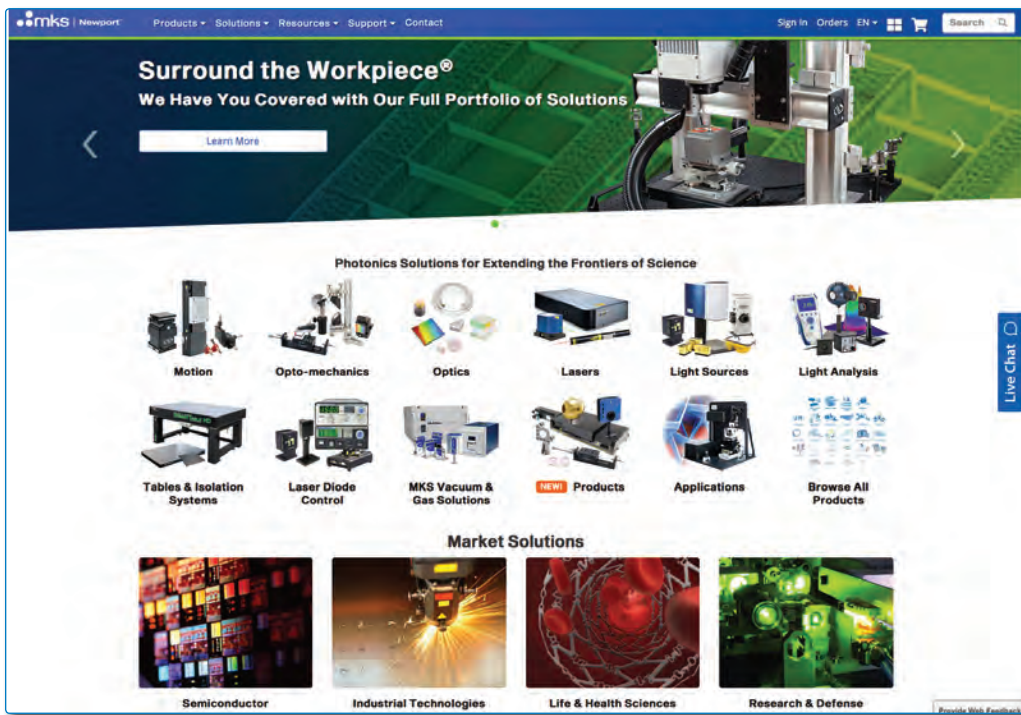

Visit us at www.newport.com to shop online and browse the latest news and events, products categories, technical information, interactive 3D CAD drawings, special offers and much more!

Precision Motion Control Catalog

Our standard motion control products are available in the shortest possible lead times and can be ordered online or by placing an order at your local Newport sales office or with your representative. To receive a free copy of the Precision Motion Control catalog, please register online at www.newport.com or contact us.



www.newport.com

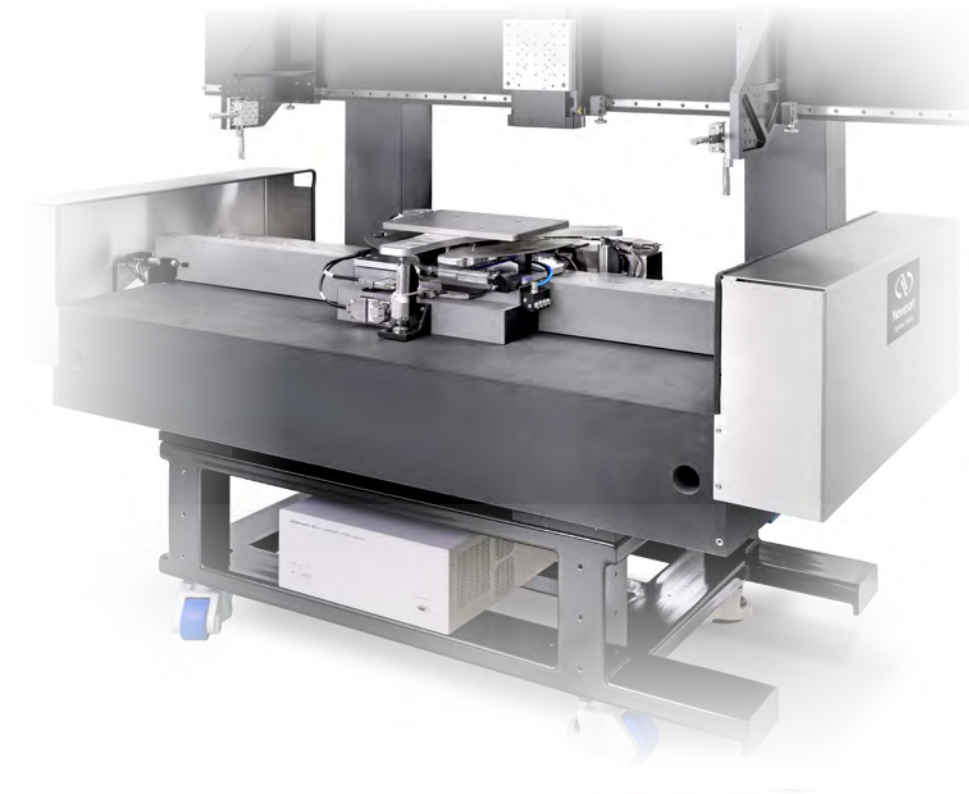

 | **Newport™** | **Ophir®** | **Spectra-Physics®**

Newport® and the Newport logo are registered trademarks of Newport Corporation in Austria, Barbados, Benelux, the Peoples Republic of China, Denmark, Germany, Ireland, Japan, the Republic of Korea, and Sweden. The Newport logo, Datum®, DynamYX®, Newport Resource®, ULTIMA® and SolaryX® are registered trademarks of Newport Corporation in the United States. Active Plane™, Agilis™, Conex™, GuideStar™, HybrYX™, iPico™, NewStep™, Picomotor™, SinguLYS and Stability™ are trademarks of Newport Corporation. Make, Manage and Measure LightSM is a service mark of Newport Corporation.

Spectra-Physics and the Spectra-Physics Logo are registered trademarks of Newport Corporation in Argentina, Australia, Benelux, Brazil, Canada, France, Germany, Israel, Italy, Japan, Norway, Sweden, Switzerland, Taiwan, the Peoples Republic of China, the United Kingdom, and the United States.